



# J&H Equipment, Inc.

## Get The Most Out of Your Screening Machine

### J&H VIBRATING BODY CENTER FEEDER

#### FEATURES:

- Feeder capacity ranges from 10 to 250 mtph
- Available in 48", 60", 72", and 84" widths to match any J&H screen size
- Dual J&H eccentric drive motors with adjustable vibratory weight settings
- Convenient all steel quick release doors allows access to the feeder interior to view the flow of material and to perform maintenance
- Feed and Discharge bellow packages along with mate flanges come standard with all feeders.

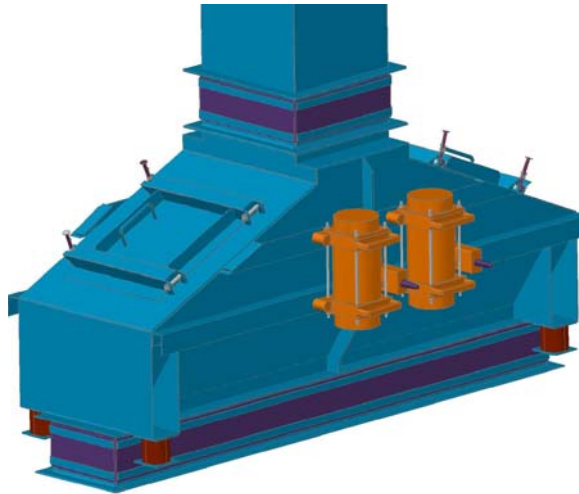

- Specifically designed to optimize material distribution to the J&H screening machine
- Latest in vibration isolation technology
- Designed for long life and ease of maintenance
- Robust construction, simple but proven design
- Manufactured utilizing state of the art robotic welders and laser cutting equipment

The J&H Vibrating Body Center Feeder is a totally enclosed machine in which the entire body and internal spreader pan vibrate as a unit. The machine bolts directly to and is supported by any J&H screen. It is mounted on four proprietary J&H vibration isolation buffers.

It is designed to increase the efficiency of a J&H screen by distributing the flow of material over the full width of its wire cloth. The vibration of the feeder is adjustable via adjustable eccentric vibratory weights which can address specific material flow needs. In addition to vibration adjustment, the J&H VBC Feeder offers adjustable feed deflectors to divert and center material flow. All come standard with access doors for ease of inspection and maintenance.

The J&H VBC Feeder is instrumental in maximizing the wire cloth life expectancy and screening efficiency.

*The J&H VBC Feeder is a proven solution for Vibrating Body Feeders, call today.*



J&H Equipment Inc. • 140 Sunshine Way • Alpharetta, GA 30005 •  
(770) 992-1606 • Fax (770) 992-1983  
Web Site: [www.jhequipment.com](http://www.jhequipment.com)

