

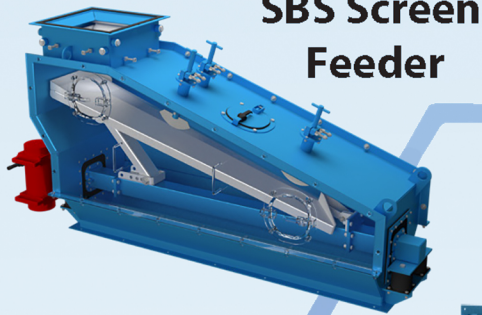

J&H EQUIPMENT INC.

The World Leader in Vibrating Wire Screens



SBS Screen Feeder

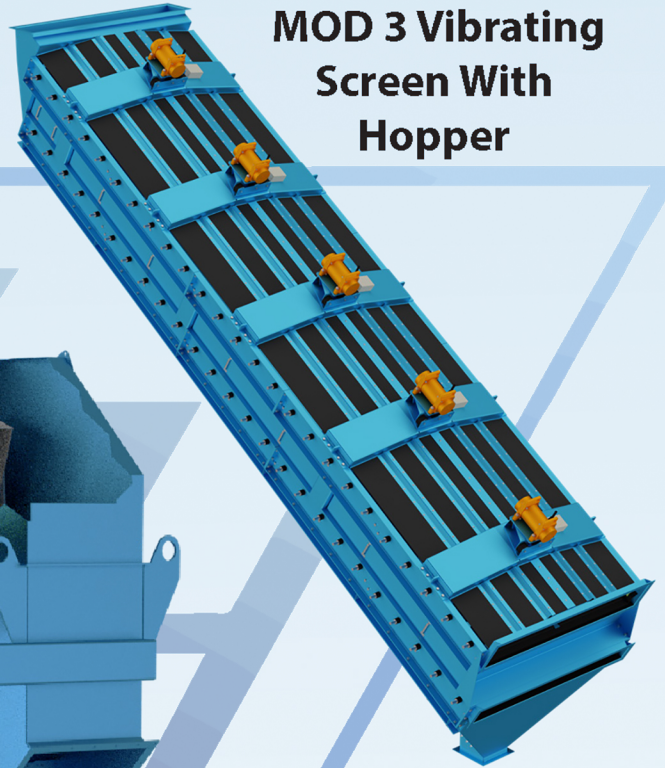

MOD 3 Vibrating Screen With Hopper

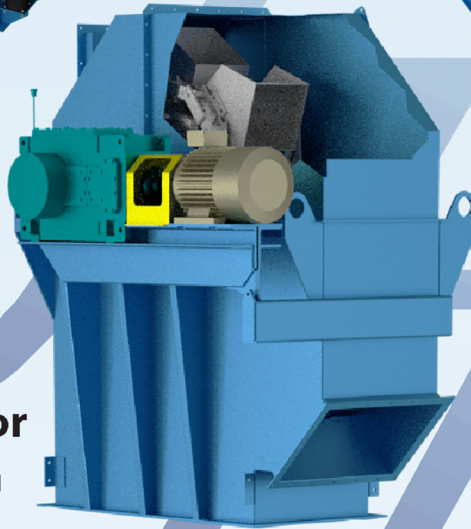

Bucket Elevator Head Section

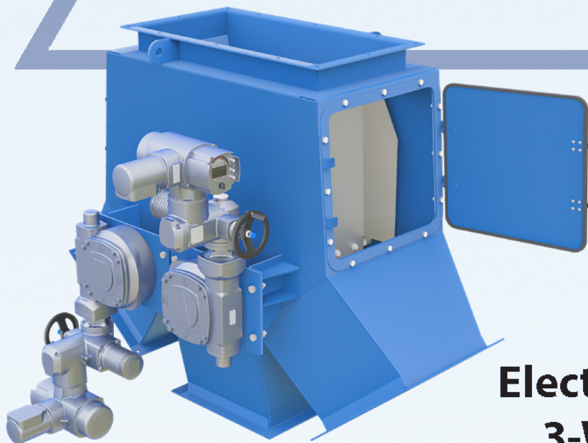

Electromechanical 3-Way Splitter

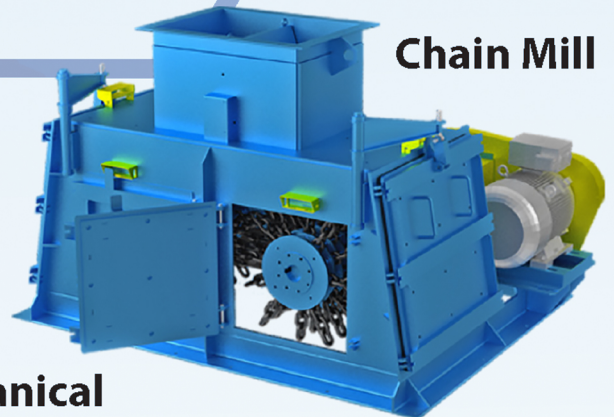

Chain Mill

COMPLETE PRODUCT LINE BROCHURE PACKAGE

J&H Equipment Inc.

140 Sunshine Way, Alpharetta, GA 30005
Phone (770) 992-1606 | Fax (770) 992-1983
Web Site: www.jhequipment.com



J&H Equipment, Inc. Industrial High Capacity Bucket Elevators

J&H Industrial High Capacity Bucket Elevators

FEATURES:

- Available in various thicknesses as required per application and loads
- Where required available with J&H custom hardened boot bearings for internal gravity take-ups
- Flanged air vents available as required
- Multiple drive scenarios available depending upon customer needs and requirements
- Numerous instrumentation options are available from overflow sensors to zero speed switches

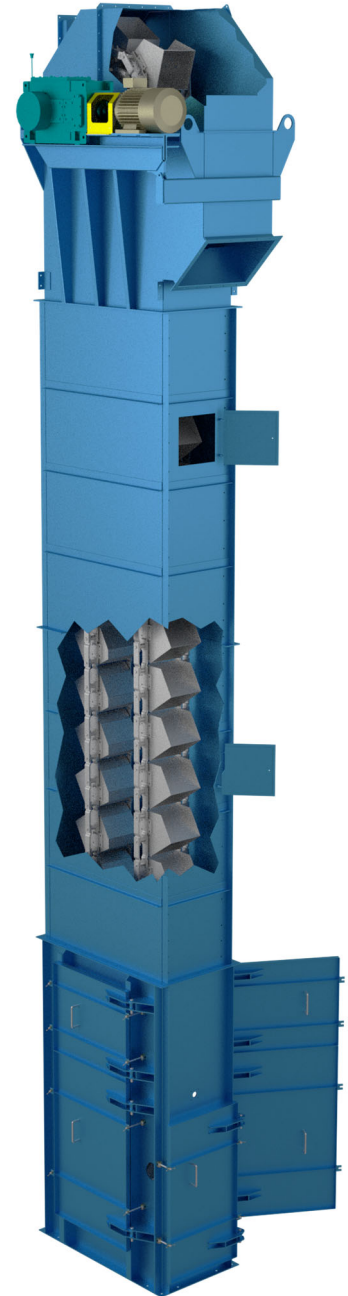

For over 35 years J&H has manufactured heavy duty bucket elevators for various industrial applications, including:

High speed, back hung, centrifugal discharge chain and belt elevators for fertilizer, cement, lime and gypsum industries.

Single and dual strand chain back hung, continuous bucket elevators with reduced speed for high capacity materials handling with minimum dust and material degradation.

Dual strand side hung high capacity continuous bucket elevators for maximum capacities with super heavy duty 9" pitch side guided steel chains, sprockets and take-up with cast bearings.



J&H Equipment Inc. • 140 Sunshine Way • Alpharetta, GA 30005 •

(770) 992-1606 • Fax (770) 992-1983

Web Site: www.jhequipment.com



J&H Equipment, Inc.

Industrial High Capacity Bucket Elevators

J&H High Capacity Belt Bucket Elevators

FEATURES:

- Robust design for heavy duty applications
- Customizable sizes according to design criteria and customer needs
- High temperature buckets and belting available
- Option for access platform and ladder system

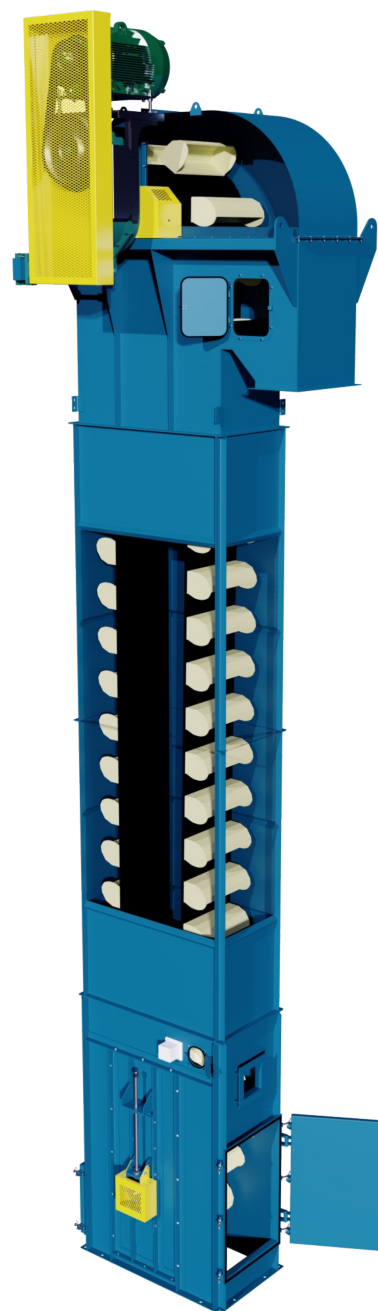
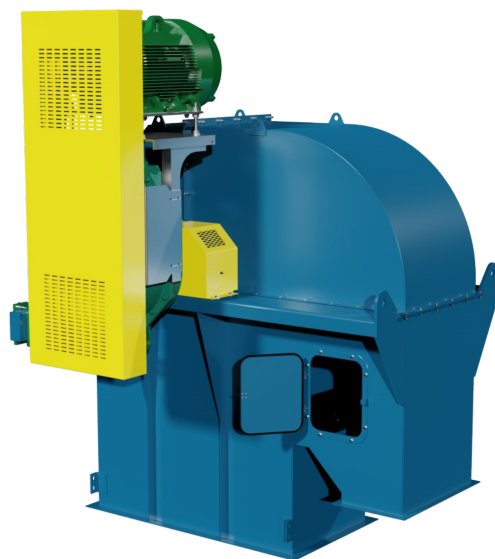

The J&H High Capacity Belt Bucket Elevator is a heavy duty, centrifugal style elevator that is ideal for moving abrasive, free-flowing, fine, and loose materials at high speeds.

Buckets are mounted on durable belting at set intervals. Material is loaded at the inlet and then centrifugally discharged as buckets pass over the head pulley.

J&H belt elevators are suitable for a wide range of applications and are sized according to material type, density, desired capacity, and lift.

J&H bucket elevators are self-supporting vertically but require lateral support to brace horizontally. Optional access platform and ladder system is available for quote upon request.

Contact your J&H representative to discuss how J&H can fulfill your bulk material handling needs.



J&H Equipment Inc. • 140 Sunshine Way • Alpharetta, GA 30005 •

(770) 992-1606 • Fax (770) 992-1983

Web Site: www.jhequipment.com



J&H Equipment, Inc.

The World Leader in Vibrating Wire Screens

FEATURES:

- J&H's unique tuned suspension system, which yields better uniformity and distribution of vibration throughout the screening surface
- Enlarged inlet and over size openings that reduce the chance of plugging
- Accessible rollback rubber covers—the first in the industry
- Vibrator motors are manufactured by J&H specifically for screening drive service
- Motor repair kit that allows the end user to rebuild old vibrators to new standards—quickly and economically
- J&H MOD III One Surface Screening Machine achieves high screening efficiencies with low power consumption cost
- Includes J&H Patented Optimizer Tensioning System pictured below



J&H MOD III SINGLE SURFACE SCREENING MACHINE

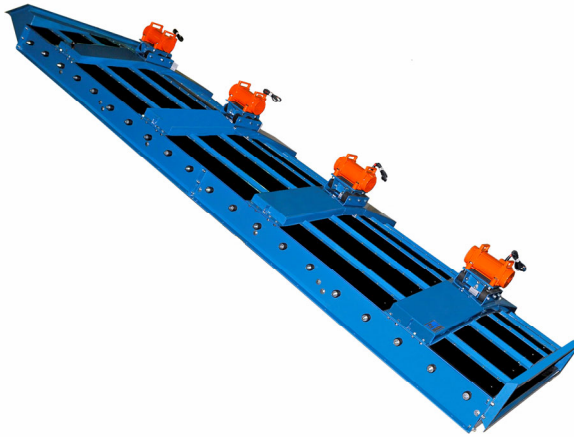

The J&H Mod III Vibrating Screens are built around our unique tuned suspension tensioning system. This system guarantees wire cloth is tensioned properly and that vibration can be evenly distributed throughout each screen panel. All of this is done with a minimum of power consumption, structural live loads and maintenance requirements.

JHV 1800 and 3600 vibrators are utilized to power MOD III screening machines, depending on size fractions being screened. The vibrators are designed and manufactured by J&H specifically for severe service continuous production chemical and mineral plants.

Incorporating 40 years of laboratory and field work, the MOD III is designed to process 8 mm (2 mesh) to .152 mm (100 mesh) material at very high capacities and with extreme accuracy.

J&H Mod III single deck machine is available in sizes from 4'x5' (1.2 m x 1.5 m) to 7'x25' (2.1 m x 7.6 m). The tensioning system and floating drive assembly allow our screens to be rigidly mounted to the supporting structure and feed and discharge chutes.

Conversion kits are available for machines built after 1983 to bring them up to today's state of the art performance.

This combination of unique features offers unparalleled screening efficiency, productivity, and durability.

- In sizes from: 3' x 5' To 7' x 25'
- Latest in vibration isolation technology
- Designed for long life and ease of maintenance, estimated life over 20 years
- Versatile and modular in construction, customizable to your needs
- Manufactured utilizing state of the art robotic welders and laser cutting equipment
- Featuring J&H's unique Tuned Suspension system for superior performance

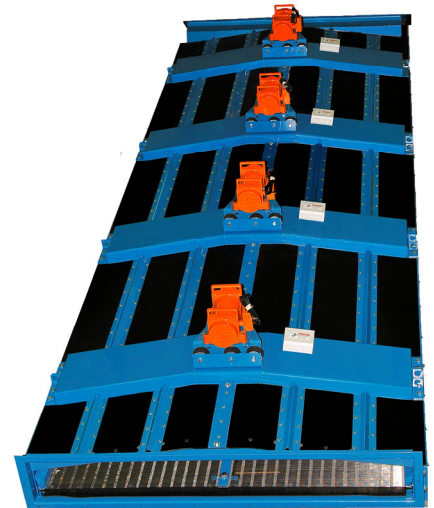



J&H Equipment, INC.

The World Leader in Vibrating Wire Screens

J&H MOD III TWO SURFACE SCREENING MACHINE

FEATURES:

- J&H's unique tuned suspension system, which yields better uniformity and distribution of vibration throughout the screening surface
- Enlarged inlet and over size openings that reduce the chance of plugging
- Accessible rollback rubber covers—the first in the industry
- Vibrator motors are manufactured by J&H specifically for screening drive service
- Motor repair kit that allows the end user to rebuild old vibrators to new standards—quickly and economically
- J&H MOD III Two Surface Screening Machine achieves high screening efficiencies with low power consumption cost
- Includes J&H Patented Optimizer Tensioning System pictured below



- In sizes from: 3' x 5' To 7' x 25'
- Latest in vibration isolation technology
- Designed for long life and ease of maintenance, estimated life over 20 years
- Versatile and modular in construction, customizable to your needs
- Manufactured utilizing state of the art robotic welders and laser cutting equipment
- Featuring J&H's unique Tuned Suspension system for superior performance

The J&H Mod III Vibrating Screens are built around our unique tuned suspension tensioning system. This system guarantees wire cloth is tensioned properly and that vibration can be evenly distributed throughout each screen panel. All of this is done with a minimum of power consumption, structural live loads and maintenance requirements.

JHV 1800 and 3600 vibrators are utilized to power MOD III screening machines, depending on size fractions being screened. The vibrators are designed and manufactured by J&H specifically for severe service continuous production chemical and mineral plants.

Incorporating 40 years of laboratory and field work, the MOD III is designed to process 8 mm (2 mesh) to .152 mm (100 mesh) material at very high capacities and with extreme accuracy.

J&H Mod III double deck machine is available in sizes from 4'x5' (1.2 m x 1.5 m) to 7'x25' (2.1 m x 7.6 m). The tensioning system and floating drive assembly allow our screens to be rigidly mounted to the supporting structure and feed and discharge chutes.

Conversion kits are available for machines built after 1983 to bring them up to today's state of the art performance.

This combination of unique features offers unparalleled screening efficiency, productivity, and durability.





J&H Equipment, INC.

The World Leader in Vibrating Wire Screens

J&H MOD III THREE SURFACE SCREENING MACHINE

FEATURES:

- J&H's unique tuned suspension system, which yields better uniformity and distribution of vibration throughout the screening surface
- Enlarged inlet and over size openings that reduce the chance of plugging
- Accessible rollback rubber covers—the first in the industry
- Vibrator motors are manufactured by J&H specifically for screening drive service
- Motor repair kit that allows the end user to rebuild old vibrators to new standards—quickly and economically
- J&H MOD III Three Surface Screening Machine achieves high screening efficiencies with low power consumption cost
- Includes J&H Patented Optimizer Tensioning System pictured below



The J&H Mod III Vibrating Screens are built around our unique tuned suspension tensioning system. This system guarantees wire cloth is tensioned properly and that vibration can be evenly distributed throughout each screen panel. All of this is done with a minimum of power consumption, structural live loads and maintenance requirements.

JHV 1800 and 3600 vibrators are utilized to power MOD III screening machines, depending on size fractions being screened. The vibrators are designed and manufactured by J&H specifically for severe service continuous production chemical and mineral plants.

Incorporating 40 years of laboratory and field work, the MOD III is designed to process 8 mm (2 mesh) to .152 mm (100 mesh) material at very high capacities and with extreme accuracy.

J&H Mod III triple deck machine is available in sizes from 4'x5' (1.2 m x 1.5 m) to 7'x25' (2.1 m x 7.6 m). The tensioning system and floating drive assembly allow our screens to be rigidly mounted to the supporting structure and feed and discharge chutes.

Conversion kits are available for machines built after 1983 to bring them up to today's state of the art performance.

This combination of unique features offers unparalleled screening efficiency, productivity, and durability.

- In sizes from: 3' x 5' To 7' x 25'
- Latest in vibration isolation technology
- Designed for long life and ease of maintenance, estimated life over 20 years
- Versatile and modular in construction, customizable to your needs
- Manufactured utilizing state of the art robotic welders and laser cutting equipment
- Featuring J&H's unique Tuned Suspension system for superior performance



J&H Equipment Inc. • 140 Sunshine Way • Alpharetta, GA 30005 •

(770)992-1606 • Fax (770) 992-1983

Web Site: www.jhequipment.com



J&H Equipment, Inc.

The World Leader in Vibrating Wire Screens

J&H MOD III RIFFLE SCREENING MACHINE

FEATURES:

- J&H's unique tuned suspension system, which yields better uniformity and distribution of vibration throughout the screening surface
- Enlarged inlet and over size openings that reduce the chance of plugging
- Riffle feed inlet, which enables our machines to double the screening area without increasing the floor space required
- Accessible rollback rubber covers—the first in the industry
- Motor repair kit that allows the end user to rebuild old vibrators to new standards—quickly and economically
- Includes J&H Patented Optimizer Tensioning System pictured below

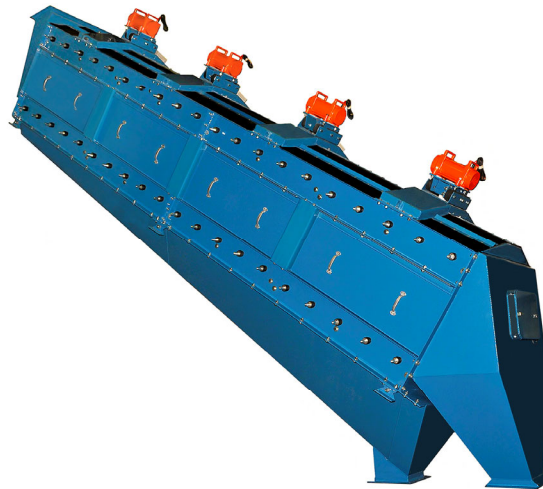
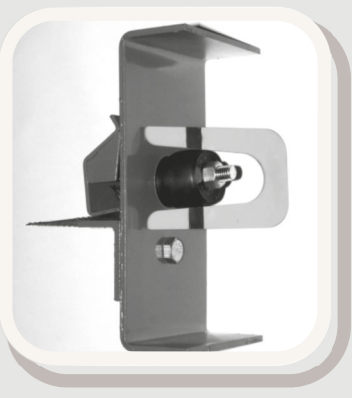

The J&H Riffle Screen is perfect for high tonnage applications. When utilizing a J&H vibrating feeder and equalizing material flow across full width of screen inlet the Riffle design becomes very advantageous in that 50% of product can be screened on top deck and 50% screened on bottom deck thus utilizing the same wire cloth/cut size on both decks. The tensioning system and floating motor allow our screens to be rigidly mounted to the supporting structure and feed and discharge chutes with negligible vibration transmissions.

The J&H Mod III Riffle Feed Vibrating Screens are built around our unique tuned suspension tensioning system. This system guarantees wire cloth is tensioned properly and that vibration can be evenly distributed throughout each screen panel. All of this is done with a minimum of power consumption, structural live loads and maintenance requirements.

JHV 1800 and 3600 vibrators are utilized to power MOD III screening machines, depending on size fractions being screened. The vibrators are designed and manufactured by J&H specifically for severe service continuous production chemical and mineral plants.

This combination of unique features offers unparalleled screening efficiency, productivity, and durability.

- In sizes from: 4' x 10' To 7' x 20'
- Industry unique riffle feed inlet allow 50% product to pass on top deck and 50% product to pass on 2nd deck.
- Latest in vibration isolation technology
- Designed for long life and ease of maintenance, estimated life over 20 years
- Versatile and modular in construction, customizable to your needs
- Manufactured utilizing state of the art robotic welders and laser cutting equipment
- Featuring J&H's unique Tuned Suspension system for superior performance





J&H Equipment, INC.

The World Leader in Vibrating Wire Screens

J&H MOD 3.5 SINGLE SURFACE SCREENING MACHINE

FEATURES:

- J&H's unique tuned suspension system, which yields better uniformity and distribution of vibration throughout the screening surface
- Dust and watertight inspection/maintenance covers.
- Quick-access covers allow for easy maintenance and wire cloth replacement. Cover removal no longer required.
- Improved drive link alignment that maximizes vibration efficiency.
- Enlarged inlet and oversize openings for reduced blockages.
- Vibrator motors are manufactured by J&H specifically for screening drive service
- Available in sizes from 4' x 5' to 7' x 25'.
- Designed for long life and ease of maintenance. Estimated life of over 20 years.



The J&H Mod 3.5 Vibrating Screens are built around our unique tuned suspension tensioning system. This system guarantees wire cloth is tensioned properly and that vibration can be evenly distributed throughout each screen panel. All of this is achieved with minimum power consumption, structural live loads and maintenance requirements.

JHV 1800 and 3600 RPM vibrators are utilized to power MOD 3.5 screening machines, depending on size fractions being screened. The vibrators are designed and manufactured by J&H specifically for severe service continuous production chemical and mineral plants.

This combination of unique features offers unparalleled screening efficiency, productivity, and durability.

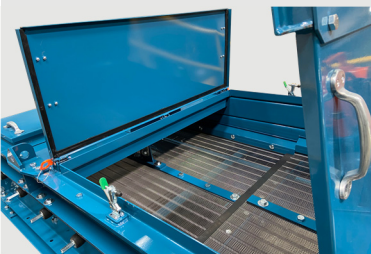

J&H Equipment Inc. • 140 Sunshine Way • Alpharetta, GA 30005 •

(770) 992-1606 • Fax (770) 992-1983

Web Site: www.jhequipment.com



J&H Equipment, INC. The World Leader in Vibrating Wire Screens

RotoThrow Oscillating Screening Machine

FEATURES:

- Available in variety of sizes, deck configurations and sieve ranges.
- Suitable for a multitude of materials and applications including:
 - Scalping
 - Oversize Separation
 - Product Screening
 - Fines Removal
- Wet and Dry Operation
- Adjustable Incline
- Isolation support feet minimize load and vibration transmitted

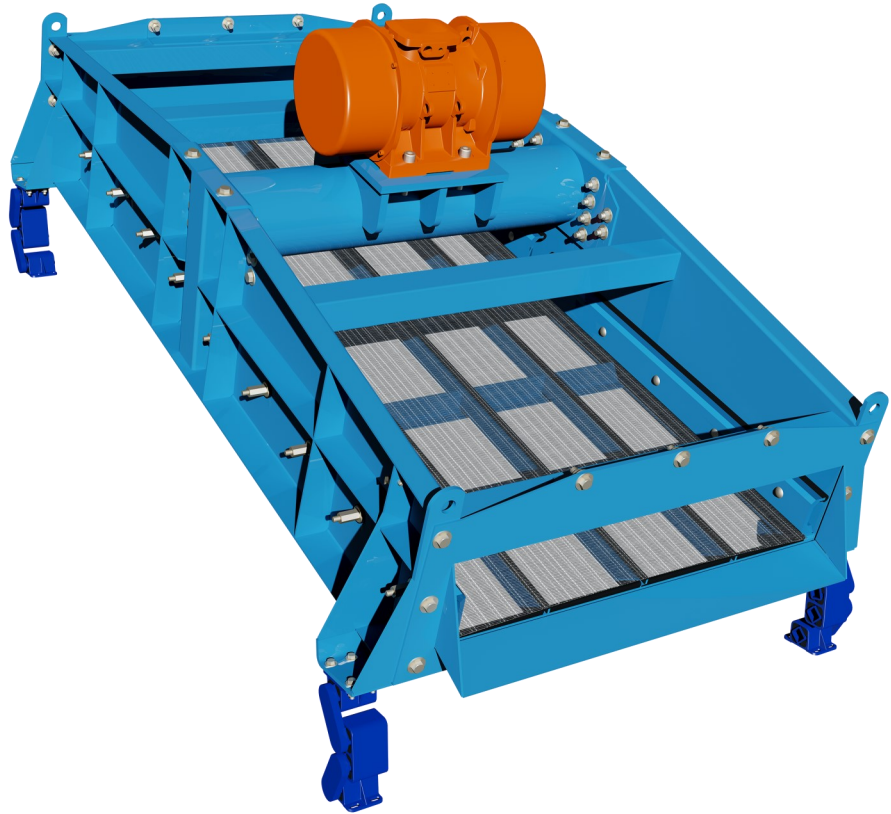

The all-new J&H RotoThrow Oscillating screening machine is a particle separator of robust construction and a simple compact design. It is ideal for processes requiring a constant force and momentum to move and segregate material. RotoThrow screening machines are equipped with suspension isolation feet that drastically reduce load and dampen vibration transmitted into the support structure

A single rotary eccentric drive with four oscillating suspension mounts generates an accelerated vector action optimizing screening and conveyance. This motion allows for high screening efficiencies with maximum throughput and low power consumption. Focused on worry free operation and easy maintenance, contact your J&H sales representative today.

Now available with heated screen option compatible with most screen heat transformers, replacement, retrofit, or new install.

J&H Equipment Inc. • 140 Sunshine Way • Alpharetta, GA 30005 •
(770)992-1606 • Fax (770) 992-1983
Web Site: www.jhequipment.com





J&H Equipment, Inc.

The World Leader in Vibrating Wire Screens

J&H SPEED CLEAN SYSTEM

FEATURES:

- Available in 50/60 Hz and 380-575, 660V.
- Robust NEMA4X/IP66 protection for harsh environmental conditions.
- Enclosures available in carbon steel & 304 stainless.
- Cleaning cycle does not interrupt production.
- Cleaning cycle interval adjustable for optimization.
- VFD and motor switch fault monitoring capability.
- Local or DCS control configurations.

INCLUDES:

- Variable frequency drive.
- Individual motor protection.
- Emergency stop.
- VFD bypass capability.
- Option to integrate J&H feeder control / interlock.



The J&H Speed clean is an integrated control system designed to increase efficiency and reduce operating cost for material processing plants that utilize J&H Screening Machines. The main function of the speed clean system is to reduce the amount of material lodged in wire cloth openings, which prevents material from being screened properly. This is achieved through the use of a variable frequency drive that periodically increases the frequency of the motors, resulting in increased energy to the wire cloth. Benefits of implementing the Speed Clean System include the following:

- Reduces maintenance downtime.
- Reduces frequency of downtime.
- Increases efficiency of screening
- Extends life of the wire cloth.

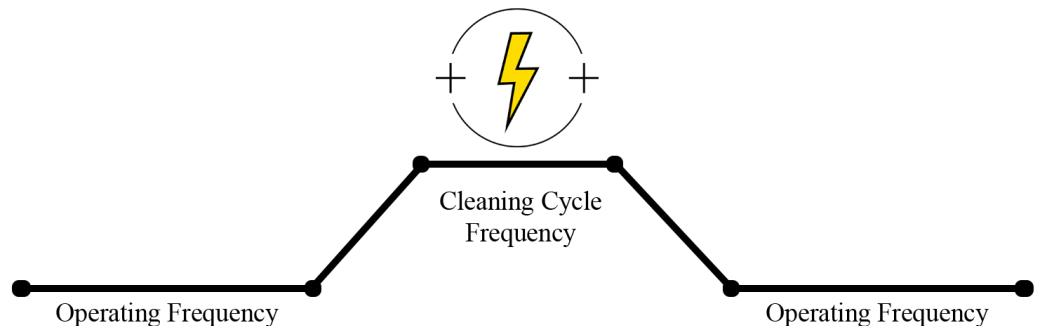



Rotary Electric Vibrators



Newly redesigned JHV super-duty vibrator with the same footprint, lower operating temperature, and improved output force. CE & CSA certifications available for select models. UL Class II, Div. II available on future models.



URAS TECHNO

Even the harshest conditions won't bother Uras Techno's rotary electric vibrators. Designed for continuous duty and protection from environmental elements, they have a reputation for ensuring maximum up-time and material flow — even with high load applications.

Uras Techno & J&H Equipment have collaborated to develop a new generation JHV vibrator. The vibrators are optimized for the J&H product line featuring a robust design that prioritizes longevity by using oversize shafts and bearings to meet the rigorous demands of the material processing industry.

BENEFITS INCLUDE

- IP66, continuous duty rating for long service life in harsh conditions
- Highly flexible with adjustable force outputs (0%–100%), frequency ranges and amplitudes
- All-weather polyurethane coating finish
- Low noise level — run at an average of 65 dB at one meter
- All units have permanently greased bearings to minimize maintenance
- Mounting fasteners and pre-installed anti-vibrational lead cable included
- All models are inverter duty rated



Certified under ISO 9001,
the international standard for quality systems



CSA standards and CE marking available

Key Details/Features of The JHV Motor

- Robust design with oversized shaft and bearings.
- Motors are designed to JIS standards, comparable to IEC.
- Improved energy consumption to output force ratio.
- Low operation temperatures.
- Simplified, quick eccentric weight adjustment.

JHV Models and Range

Model	No. of Poles	Frequency (Hz)	Vibrating Force (lbf)	Vibrating Force (kN)	Available Voltage (V)	Speed (rev/min)	Paint Color	Certification	Ouput (HP)	Output (kW)
17-114-A	4	(50)/60	1798	8	(380)/(400)/(415)/230/460	1500 @ 50 Hz / 1800 @ 60 HZ	Red	CE	0.8	0.6
17-114-B		60			575			CSA		
17-114-C		50			380/660			None		
17-115-A	2	(50)/60	2698	12	(380)/(400)/(415)/230/460	3000 @ 50 Hz / 3600 @ 60 HZ	Orange	CE		
17-115-B		60			575			CSA		
17-115-C		50			380/660			None		

Construction

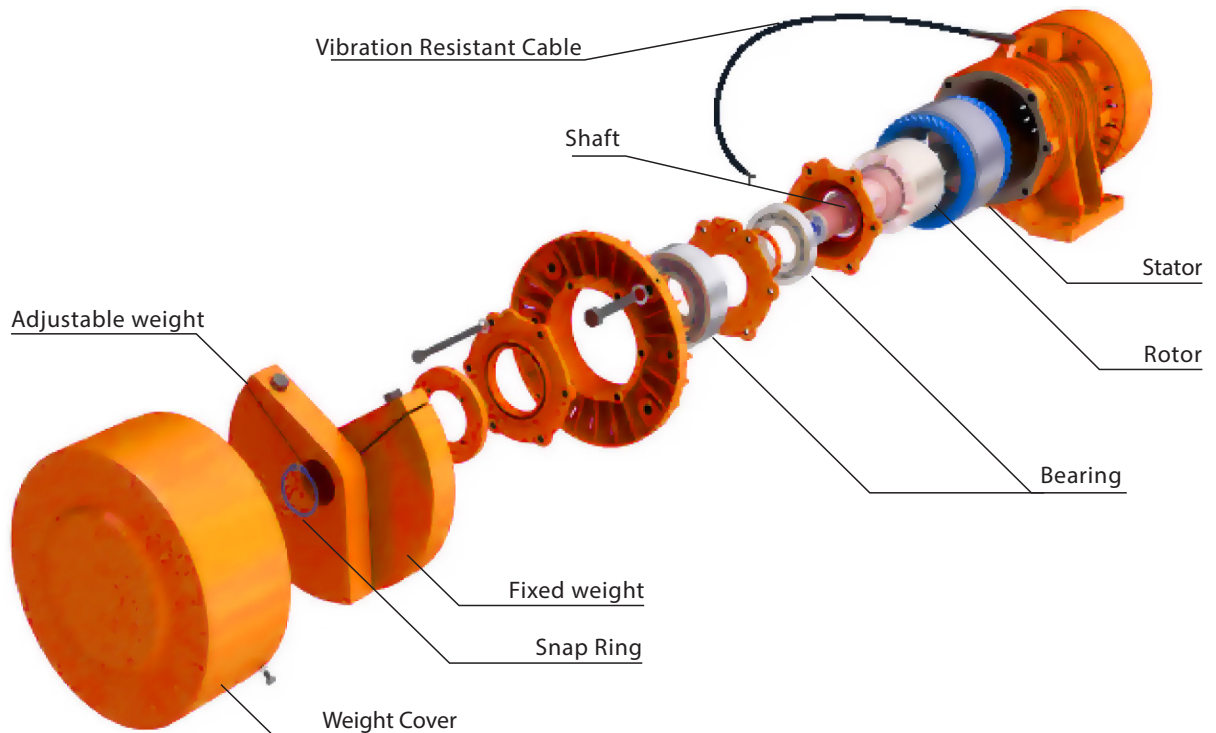

Uras Vibrators feature an extremely simple mechanism whereby vibrating force is created by rotating unbalanced weights attached to both ends of an induction motor shaft. Drawing on research and a proven track record that spans a half-century since our vibrators were originally developed, we have perfected vibrators with tough vibration resistant structures and an extremely high level of reliability.

These vibrators have been designed to prevent the unbalanced weights from dropping down during adjustment, ensuring complete safety when handling. Additionally, this design feature helps to extend the service life of the bearings, usable under all weather conditions.

Standard Specifications of JHV Series

Specification	Three-phase	
	2 Poles	4 Poles
Power Supply	230/380/400/415/460/575/660	
Time Rating	Continuous rating	
Thermal Class	Class F	
External Cover Structure (Vibrating Force kN)	12	8 to 10.5
Protection Structure	IP66	
Output (kW)	0.6	
Speed	Power Supply Frequency (Hz)	
	50/60	
	(r/min)	
	3000/3600	1500/1800
Vibrating Force (kN)	12	8
Vibrating Force (lbf)	2698	1798
Sealed ZZ Bearings Vibrating Force (kN)	12	8 to 10.5
Enclosed Cable	2PNC2 (4-core) x 2m cable	
Installation Method	Frame leg installation	
Coating Color	J&H Orange	J&H Red
Installation and Operating Environment	Can be used indoors and outdoors. Ambient (including installation base) temperature: -15°C to +40°C* Altitude: 1,000 m max. Relative humidity: 85% max. with no condensation	

* Please contact J&H for applications subject to temperatures below -15°C or above 40°C.

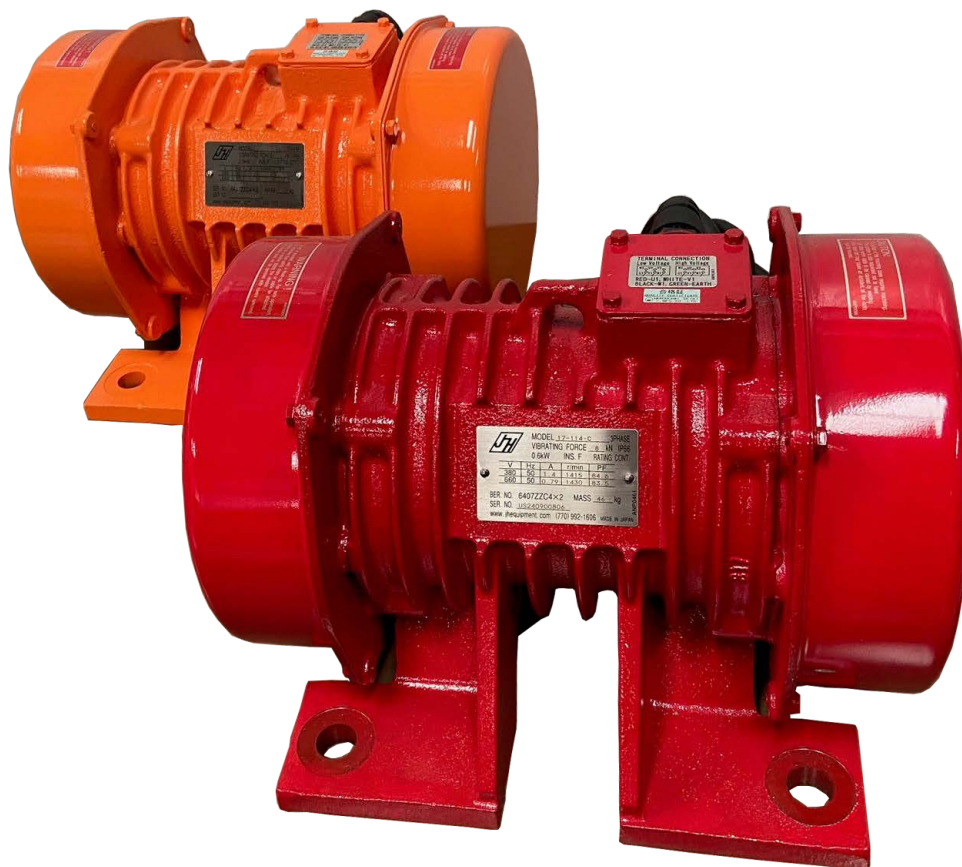

JHV Standard Uras Vibrators

Model	Full-load Current (A)														Protection Structure
	230 Volt		380 Volt		400 Volt		415 Volt		460 Volt		575 Volt		660 Volt		
	50 Hz	60 Hz	50 Hz	60 Hz	50 Hz	60 Hz	50 Hz	60 Hz	50 Hz	60 Hz	50 Hz	60 Hz	50 Hz	60 Hz	
17-114-A	-	2.4	1.5	-	1.4	-	1.4	-	-	1.3	-	-	-	-	
17-114-B	-	-	-	-	-	-	-	-	-	-	-	0.84	-	-	
17-114-C	-	-	1.5	-	-	-	-	-	-	-	-	-	0.85	-	
17-115-A	-	2.3	1.4	-	1.4	-	1.3	-	-	1.2	-	-	-	-	
17-115-B	-	-	-	-	-	-	-	-	-	-	-	0.84	-	-	
17-115-C	-	-	1.3	-	-	-	-	-	-	-	-	-	0.72	-	

* Minimum cable bending radius, 4" [100mm] per machine manual.



Vibrator Speed

Power supply frequency of 50 Hz
Power supply frequency of 60 Hz



Vibrator Speed

Power supply frequency of 50 Hz
Power supply frequency of 60 Hz

Specifications (Imperial)

Model	Vibrating Force (lbf)	Output (HP)	No. of Poles	Dimensions (Inch)												Mass (lbs)
				A	B	C	D	E	F	G	H	I	J	K	Bolt Dia.	
17-114-A	1798	0.8	4	11.417	9.528	11.024	8.504	0.866	8.787	2.559	13.661	5.354	9.961	8.543	3/4" - 16 UNF	101.4
17-114-B			4													99.2
17-114-C			4													101.4
17-115-A	2698	0.8	2	11.417	9.528	11.024	8.504	0.866	8.787	2.559	13.661	5.354	9.961	8.543	3/4" - 16 UNF	90.4
17-115-B			2													88.2
17-115-C			2													90.4

Specifications (Metric)

Model	Vibrating Force (lbf)	Output (HP)	No. of Poles	Dimensions (mm)												Mass (kg)
				A	B	C	D	E	F	G	H	I	J	K	Bolt Dia.	
17-114-A	1798	0.8	4	290	242	280	216	22	223	65	347	136	253	217	M18*	46
17-114-B			4													45
17-114-C			4													46
17-115-A	2698	0.8	2	290	242	280	216	22	223	65	347	136	253	217	M18*	41
17-115-B			2													40
17-115-C			2													41

* J&H standard bolt supply is 3/4" - 16 UNF. Metric equivalent is M18 (Type 8.8), to be used at customer's discretion.

Outline Drawings

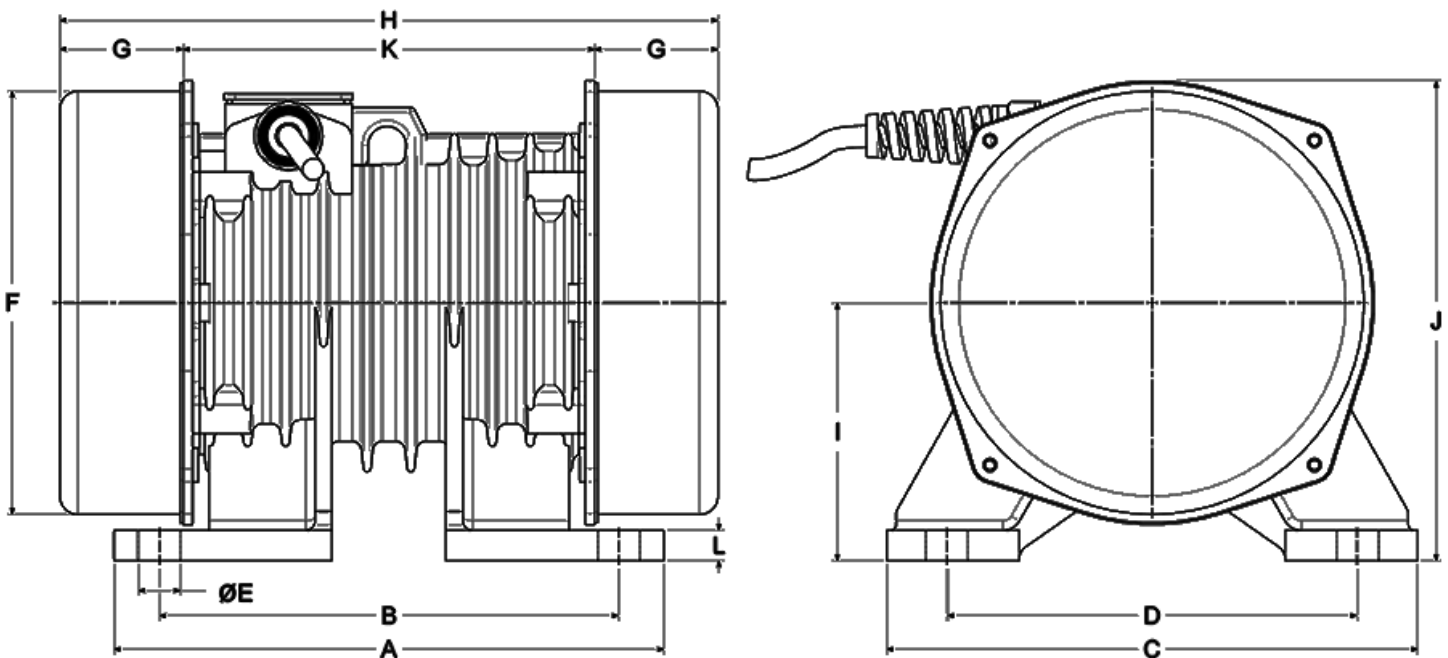

How to Adjust the Vibrating Force

Fan-shaped Weight Adjustment

The shaft uses unbalanced weights attached at both ends. As shown in the photo below, one fixed weight and one adjustable weight are attached to each end of the shaft. To adjust the vibrating force of the Uras Vibrator, the combined eccentric moment of the fixed and adjustable weights can be tuned by changing the relative angle of both weights. The adjusted angle of the weights at each end of the shaft must match.

The required vibrating force can be set by loosening the locking bolt (used to secure the adjustable weight) and aligning the indicator with the required scale marking on the scale plate. The photo shows an example of an adjustment to 40% of the maximum vibrating force at 60 Hz.

Fan-shaped weight system

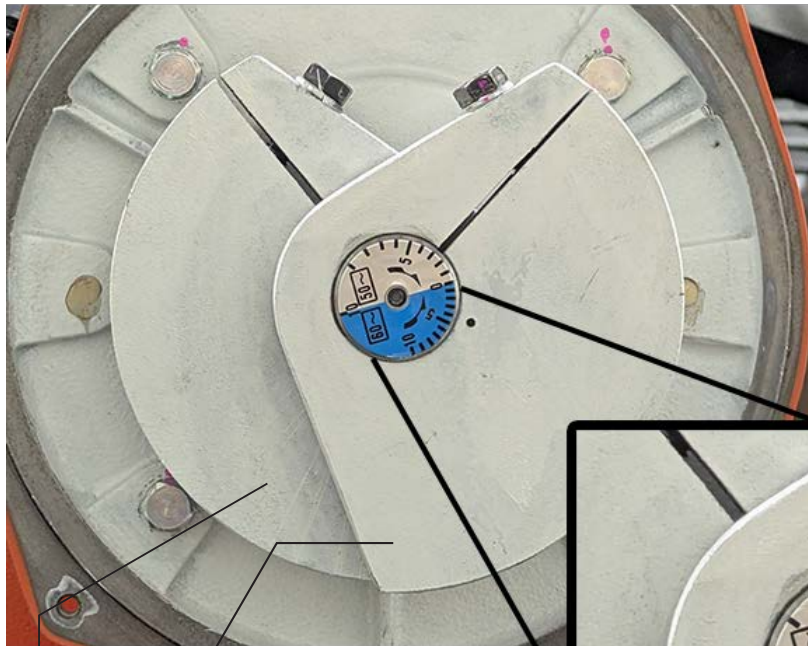

Scale Plate
(The example given here shows
a vibrating force of 40% at 60Hz)

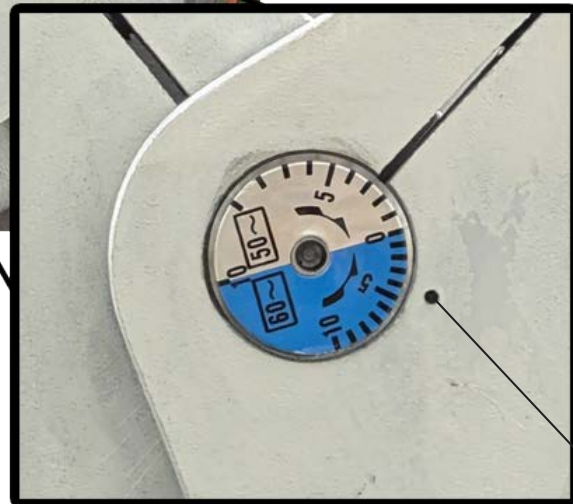

Indicator

Terminal Box and Cable

Uras Vibrator terminal boxes are filled with a special foam. The lead cable is an anti-vibration butyl rubber insulated chloroprene cab-tire that ensures long life.

	Part Name		Part Name
1	2PNECT (anti-vibration butyl rubber insulated chloroprene cab-tire cable)	6	Single-core, lead-in wire
		7	Ground wire
		8	Insulated closed-end connector
2	Rubber bushing	9	Isolation Foam
3	Bellmouth		
4	Strain Relief	10	Terminal Box Cover
5	Frame		

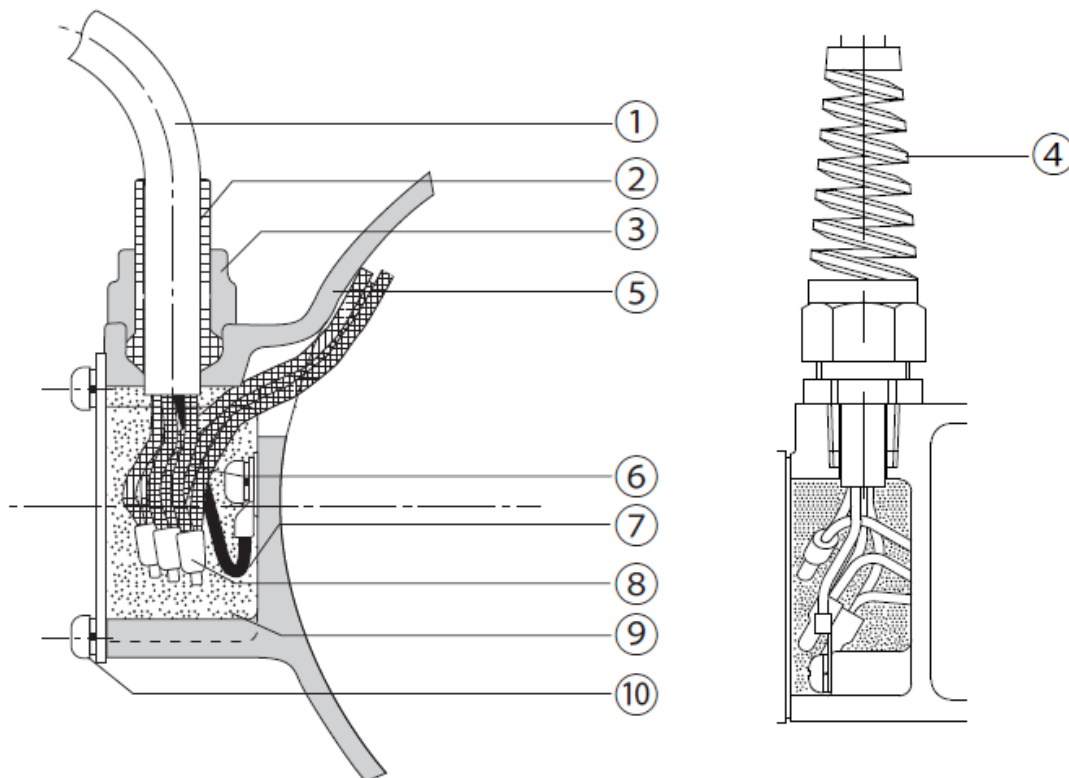

The World Leader In
Vibrating Wire Screens

FOR MORE INFORMATION

Call: 770-992-1606

Email: jhsys@jhequipment.com

Website: www.jhequipment.com



J&H Equipment, Inc. Vector Screening Your Scalping Solution

J&H VECTOR DRIVE SCREENING MACHINE

FEATURES:

- In sizes 3'x5' to 5'x8'
- Totally enclosed, dust free
- Adjustable rotary vibrators
- Extremely quiet
- Easy access, top covers totally removable
- Proven side tension design enabling use of standard wire cloth hook strips

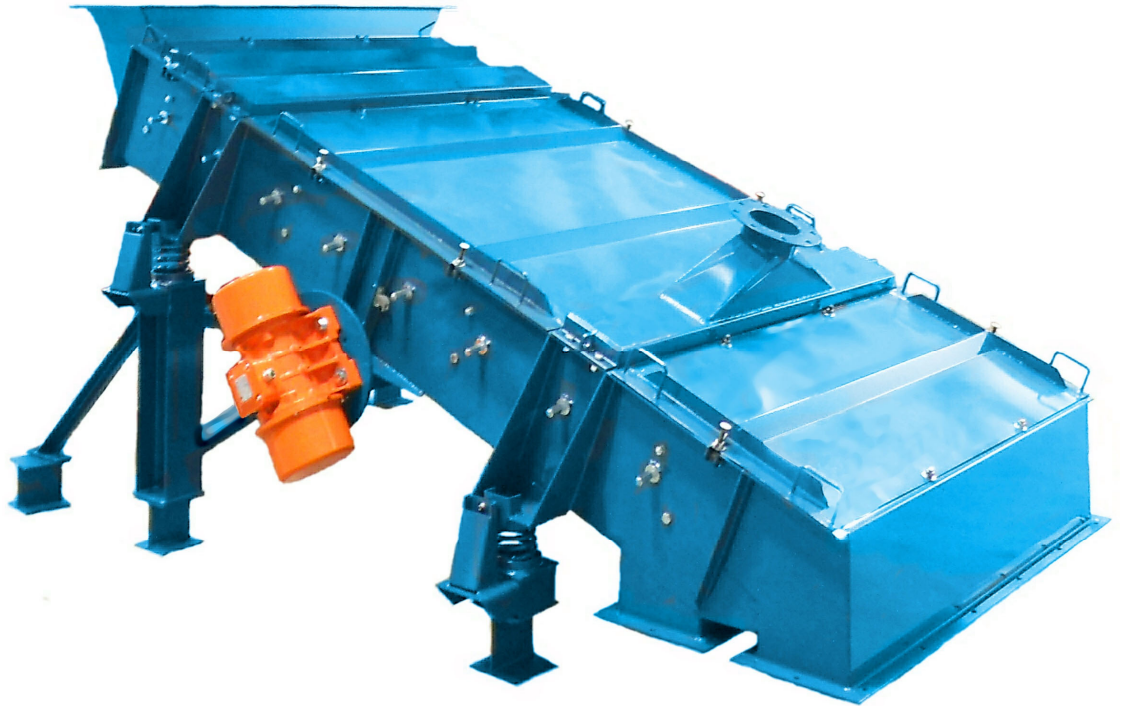

The J&H Vector Drive Screen is an ideal solution for your scalping needs. Efficient proven drive system and its simplistic and robust design propel the vector drive as an industry leader.

Drive energy is generated by unbalanced vibrators with variable weights for controlled amplitude adjustment of the machines dynamic linear action.

This combination of unique features offers unparalleled screening efficiency, productivity, and durability for your 30 to 100mm scalping requirements.

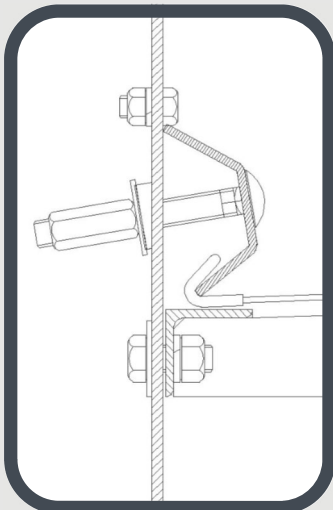

J&H Equipment Inc. • 140 Sunshine Way • Alpharetta, GA 30005 •
(770) 992-1606 • Fax (770) 992-1983
Web Site: www.jhequipment.com



J&H Equipment, Inc.

The World Leader in Vibrating Wire Screens

J&H "OPTIMIZER" TENSIONING SYSTEM

FEATURES:

- Patented tensioning system sets J&H apart from other screen manufacturers
- Easily and efficiently optimize tension and vibration throughout wire cloth
- Rubber formulated for our buffers is impervious to heat up to 300°F
- Unlike steel springs, with the J&H rubber buffer neither corrosion nor stress relief are an issue.

DON'T BE LEFT BEHIND:

Today's markets demand the highest efficiencies and productivity. All new J&H machines come standard with the J&H optimizer tensioning system. If you have an older J&H machine don't worry, you too can implement and upgrade your existing machine. J&H has taken special considerations to make the optimizer tensioning system retro-fit to previous J&H screen models. If you have a screening machine from another manufacturer you too may be able to take advantage of this patented system, J&H offers conversion kits with you in mind.



Finally a system that will yield accurate uniform tension of your wire cloth.

With the J&H Optimizer Tensioning System wire cloth can be tensioned to the optimum tension for your particular wire cloth. With true uniform tension throughout the screening machine, a new level of performance and consistency of vibration can be obtained.

When a wire cloth is installed into a J&H screen machine, a set of five rubber tensioning buffers on each side of the screen load the tension onto the wire cloth. These rubber buffers act like springs, compressing in direct proportion to the tension applied to the wire cloth. Using our unique "optimizer" tensioning gauge, the compression of the rubber buffers can be read and then adjusted to an accurate tension value, providing proof of uniformity throughout the wire cloth. This combination of unique features offers unparalleled screening efficiency, productivity, and durability.

Maximize your productivity today with the patented J&H "Optimizer" Tensioning System.



J&H Equipment Inc. • 140 Sunshine Way • Alpharetta, GA 30005 •
(770) 992-1606 • Fax (770) 992-1983
Web Site: www.jhequipment.com



J&H Equipment, Inc. Frac Sand Plants

J&H Frac Sand Plants

FEATURES:

- Standard supply includes dump valve, bucket elevator, support and access structure, material stream splitter, screening machines, fines collecting hoppers, and all necessary chute-work.
- Durable robust abrasion resistant construction.
- The J&H Material Stream Splitter provides equalized separation of material to all screening machines.
- The J&H Frac Sand Screening Machine increases efficiency through its uniform high frequency vibrations along with its patented tune suspension and “optimizer” tensioning system.
- Additionally, J&H High Capacity Bucket elevators are available to meet bulk material storage and load out requirements.



- J&H Frac Sand Plants provide a single-source solution for the frac sand processing industry.
- J&H dry screening plants provide high output efficiency with low power consumption cost.
- Versatile design allows for a customizable plant with a minimized lead time.
- Dry screening plants available ranging from 75TPH to 1200TPH and expandable as required to meet demand.
- Designed for ease of maintenance and optimal efficiency.
- Process screen systems specializing in 40/70 and 100 mesh separation are available. Scalping screen systems are also available for purchase.

- J&H is equipped with an in-house product testing facility to determine optimal wire cloth for screening machines.
- The J&H engineering team has over 40 years of experience in material handling, priding itself on swift solutions to client needs.



J&H Equipment Inc. • 140 Sunshine Way • Alpharetta, GA 30005 •
(770) 992-1606 • Fax (770) 992-1983
Web Site: www.jhequipment.com



J&H Equipment, INC.

The World Leader in Vibrating Wire Screens

SCREEN SUPPORT STRUCTURE

FEATURES:

- Provides necessary and ease of access to all inspection and maintenance points
- Designs are in accordance with OSHA/MSHA code
- Customizable for single or multiple consecutive screen banks, elevated equipment platforms
- Modular construction for ease of assembly
- AISC & IBC codes and standards followed
- AWS certified welders
- Grating and stair treads available in hot dip galvanized steel and FRP
- Industrial powder coat/wet paint, and hot dip galvanized options available.



J&H offers a full range of screen support structures for all types of J&H Screens. The structure is designed to fully support the weight of the screen, hopper, and feeder while providing necessary access at all inspection and maintenance points.

Support structures packages include all structural members, stair treads, grating, and handrails, and safety gates/ladders in accordance with OSHA/MSHA standards. Load information is provided for civil purposes.

J&H structures can accommodate single or multiple consecutive screen banks, customizable to meet specific needs. Although support structures are designed to free standing, they can be modified to tie into existing plant structures and work around existing constraints and obstacles.

J&H's in-house engineering team is ready to provide solutions to meet your needs.



J&H Equipment Inc. • 140 Sunshine Way • Alpharetta, GA 30005 •
(770)992-1606 • Fax (770) 992-1983
Web Site: www.jhequipment.com





J&H Equipment, Inc.

The World Leader in Vibrating Wire Screens

J&H Fines Hopper with Modulating Recycle Control Valve

FEATURES:

- Collects and regulates the flow of the recycle from the screening process
- Stabilizes recycling curve
- Minimizes feedback of product into recycle loop
- Reduces oversize production
- Optimizes liquids/solids balance in granulator
- Linear pneumatic or rotary electromechanical modulating actuators
- Bolts directly to the standard J&H Vibrating Screen
- Carbon steel construction coated with, industrial, powder coat
- Stainless steel divider blade
- Full-width access for maintenance and blade removal
- Lateral quick release access door for "in production" inspections

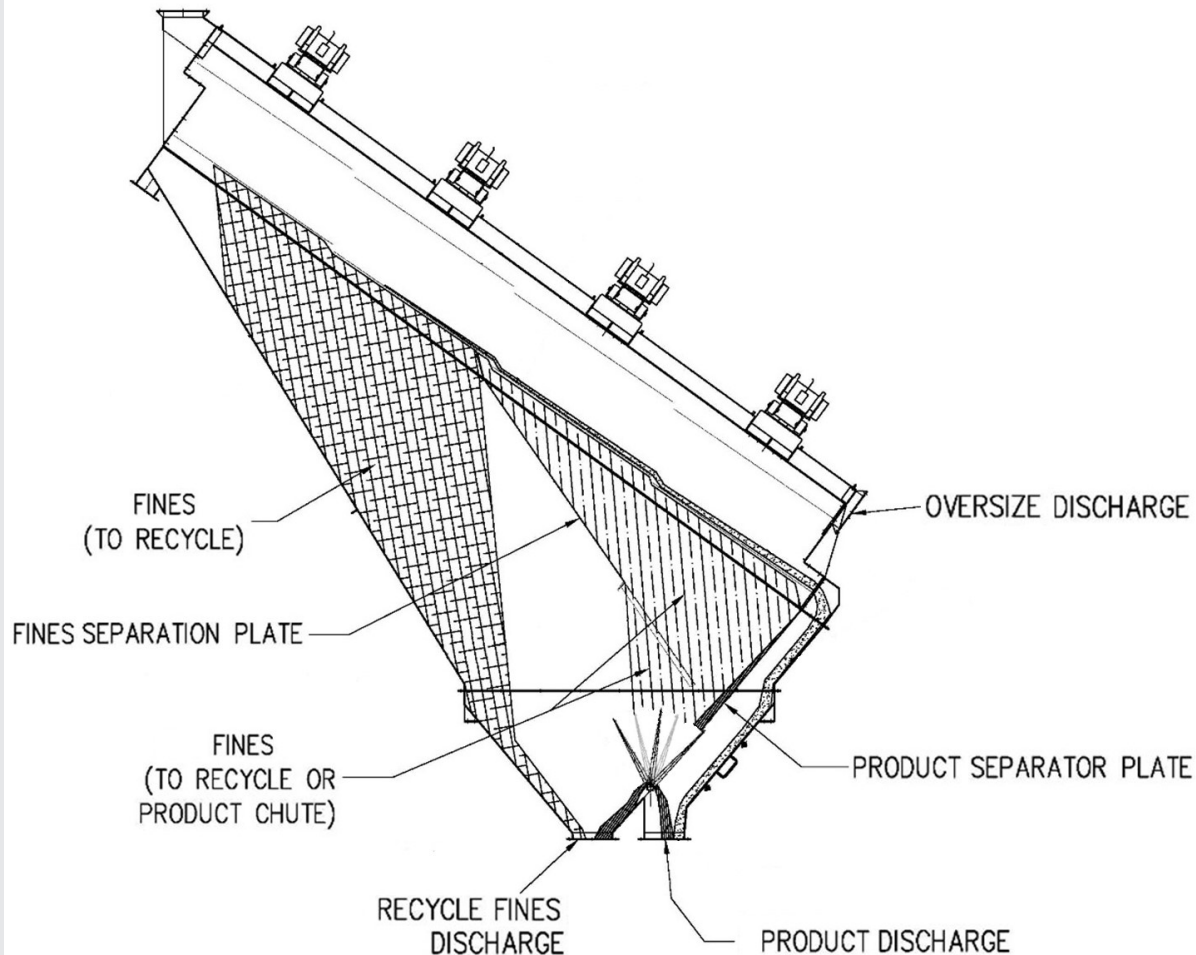

The J&H Fines Hopper with Modulating Recycle Control Valve is a special collection hopper that bolts under any J&H screening machine. Inside the hopper is an angular separation plate, which ensures optimal material cut from the modulating control gate located below the hopper discharge.

The separation plate in the main body of the hopper directs the material falling through the lower two panels of the screen bottom deck into the valve portion of the hopper. The divider blade of the control valve diverts, or splits, the flow of material into recycle and/or product.

Bolting up directly under any J&H screen, this hopper is full width of the screening machine and allows for a full-width divider blade. The width is an advantage as the gate can peel off an accurate percentage of the recycle/fines material. Such capability allows operator to select size and quantity of material being sent back to recycle.

J&H Equipment Inc. • 140 Sunshine Way • Alpharetta, GA 30005 •
(770) 992-1606 • Fax (770) 992-1983
Web Site: www.jhequipment.com

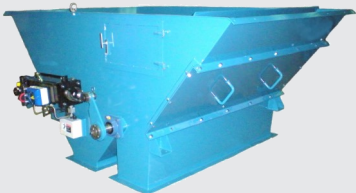



J&H Equipment, Inc.

Material Distribution Made Easy

J&H Material Diverter

FEATURES:

Modulating Diverter

- Modulation capability 0-100% of stroke
- Electromechanical linear or pneumatic actuator
- 4 to 20 mA position signal input and feedback signal

Non-modulating Diverter

- Fixed positions
- Electromechanical linear or pneumatic actuator

Common Features

- 2 or 3 discharge ports
- Carbon steel powder coated body
- Full-width access doors on each side
- Stainless steel blades or bucket
- Optional IP65 independent limit switch for position confirmation
- Capacity ranges from 50 to 200 tons per hour
- Control can be as simple as a local control box or can be integrated in the DCS control system with live feedback

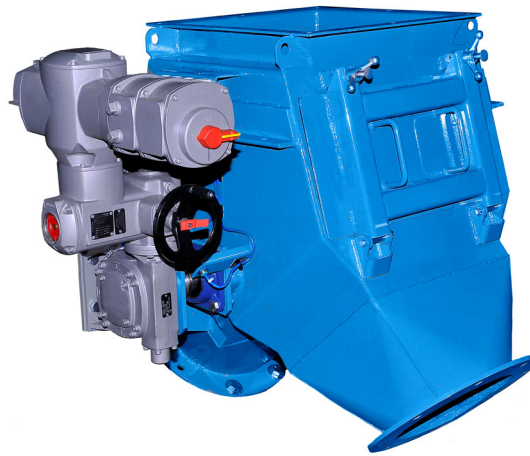

J&H Material Diverters accommodate all types of material splitting or material distribution needs. Built with two or three discharges, our valves will handle from 50 to 800 tph and up of dry, loose material. Actuators position diverting blades or buckets in order to divide or divert the input stream of material as required for downstream demands. Actuator power feed can be electrical or pneumatic in both fixed position and in modulating versions.

J&H Material Diverters will adapt to all situations and can be used as dump valves, splitting valves, distributing valves, recycling control valves, bucket valves, and more. Their robust design will provide faithful service for years with a minimum of setup or maintenance intervention required.

J&H Material Diverters are divided into two families: modulating “smart valves” and “fixed position” non-modulating valves (open/close only travel). J&H modulating “smart valve” material diverters are available with a linear or rotating electromechanical actuator or a modulating pneumatic actuator. Standard command signal and feedback is 4 to 20 mA. J&H fixed-position material diverters are available with linear or rotary electromechanical or back-to-back or single pneumatic actuators. Built with a body of carbon, stainless, or AR400 steel, the valves are coated with a durable, industrial powder coat. Internal blades or buckets are made of stainless steel. All our diverters are built with full-width access doors to allow for easy cleanup or access to the internal components. Control can be as simple as a local control box or can be integrated into a DCS system control with live feedback. Optional independent IP65 limit switches are available for position confirmation of fixed position valves.





J&H Equipment, Inc.

Maximize Efficiency with the Material Stream Splitter

J&H MULTI-SCREEN STREAM SPLITTER

FEATURES:

Modulating Stream Splitter

- Modulation capability 0-100% of stroke
- Electromechanical linear or pneumatic actuator
- 4 to 20 mA position signal input and feedback signal

Non-modulating Stream Splitter

- Fixed positions
- Electromechanical linear or pneumatic actuator

Common Features

- 3, 4, 5, or 6 discharge ports
- Carbon steel powder coated body
- Full-width access doors on each side
- Stainless steel blades
- Optional IP65 independent limit switch for position confirmation
- Capacity ranges from 50 to 800 tons per hour
- Control can be as simple as a local control box or can be integrated in the DCS control system with live feedback

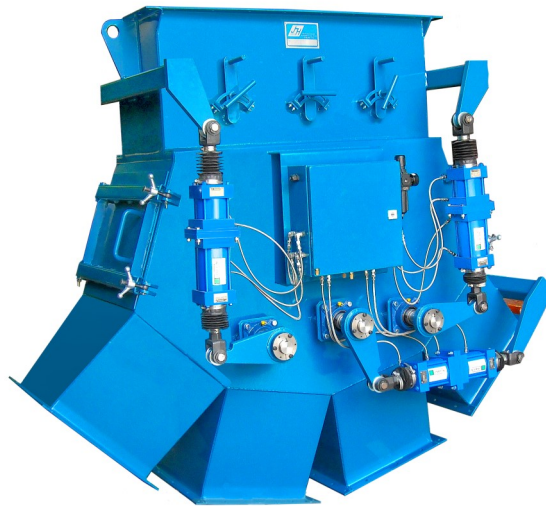

Stream Splitters – like other J&H diverters – are divided into two families: modulating and non-modulating (open/close only travel) with fixed positions. J&H modulating Stream Splitters are available with a linear electromechanical actuator or a modulating pneumatic actuator. Standard command signal and feedback is 4 to 20 mA. J&H fixed-position Stream Splitters are available with linear electromechanical or back-to-back pneumatic actuators. Built with a body of carbon, stainless, or AR400 steel, they are coated with a durable, industrial powder coat. Internal blades are made of stainless steel. All our splitters are built with full-width access doors to allow for easy cleanup or maintenance of internal components. Control can be as simple as a local control box or can be integrated into a DCS system control with live feedback. Optional independent IP65 limit switches are available for position confirmation.

The J&H Stream Splitter is a unique machine designed specifically to feed material to multi-screen installations. Built with three, four, five, or six discharges, our stream splitters will handle from 50 to 800 tph and up of dry, loose material. Actuators maneuver multiple splitting blades in order to divide the input stream of material into equal downstream screen feed requirements. Actuator power can be electrical or pneumatic in both fixed position and modulating versions. J&H Stream Splitters are designed for today's demanding production requirements. The Stream Splitter enables the customer to evenly divide the flow of material into 3, 4, 5, or 6 streams and minimizes height requirements and the need for multiple splitters to try to achieve the same outcome. Another revolutionary feature of the J&H Stream Splitter is its ability to shut off flow to a single screen line while instantly equalizing flow to remaining screen lines. This innovative design allows the end user to perform maintenance on that line or its crusher below without slowing or stopping production of the entire plant.

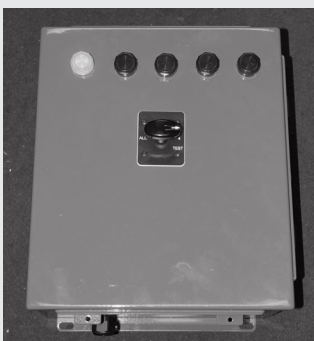
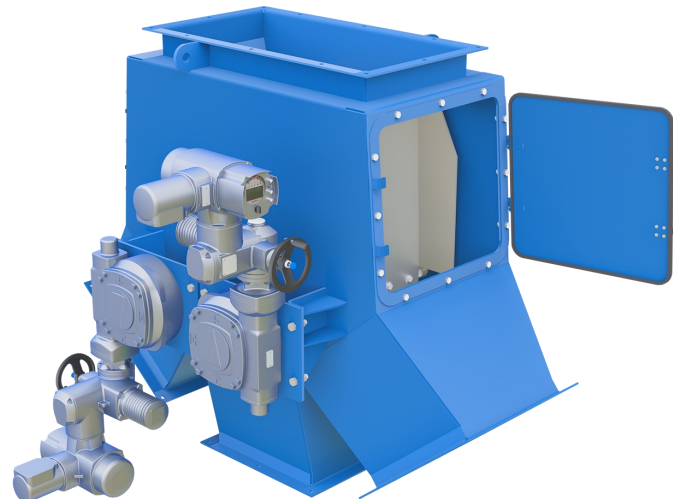

J&H Equipment Inc. • 140 Sunshine Way • Alpharetta, GA 30005 •

(770) 992-1606 • Fax (770) 992-1983

Web Site: www.jhequipment.com



J&H Equipment, Inc.

Material Distribution Made Easy

J&H Multiport Rotary Valve

FEATURES:

Multiport Actuator

- Programmable positions
- Electronic positioning
- Position and fault indicating feedback signals to Control Room
- Locally controlled maintenance positions

Common Features

- 4 to 6 discharge ports
- Carbon steel powder coated body, stainless option available
- Large access doors on each side
- Capacity ranges from 50 to 800 tons per hour
- Local control or DCS integration options
- Outlet chutes designed to prevent leakage/buildup in body

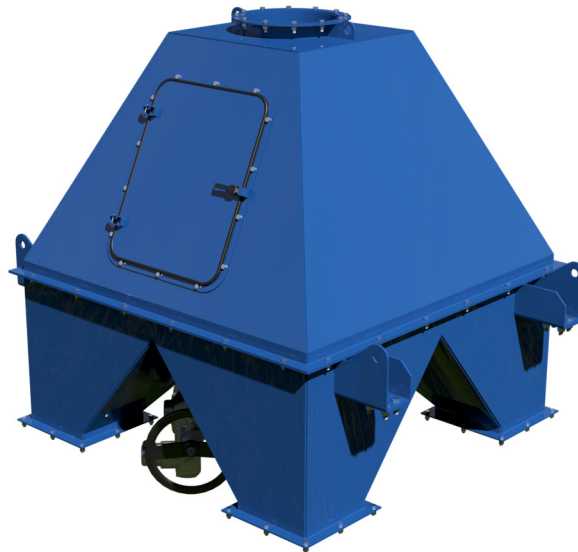

J&H Multiport Rotary valves use a rotary mounted internal chute to direct material from one feed chute into four, five, or six radially directed discharge ports. J&H valves will handle from 50 to 800 tph and up of dry, loose material. An electronically controlled and programmed actuator positions the rotary chute to align with each port according to digital input command signals.

J&H Multiport Rotary valves are designed for ease of operation and reliability. Electronic controller monitors the position and sends out digital and analog signals that can be observed from the control room. The robust design provides reliable service for years with minimum maintenance required.

J&H Multiport Rotary valves are individually designed and engineered to accommodate customer requirements of plant layout, chute size and orientation, and type of product material. Built with a body of carbon steel, the valves are coated with a durable, industrial powder coat. Internal chutes are made of carbon or stainless steel. Feed and discharge port flanges designed to match customer chute work.

All J&H diverters are built with large access doors to allow for easy access to the internal components. An optional local control box can supplement and simplify control at the actuator.

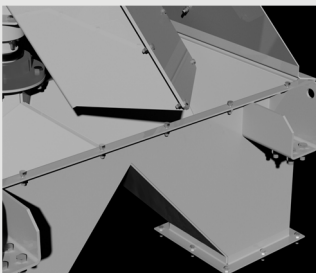
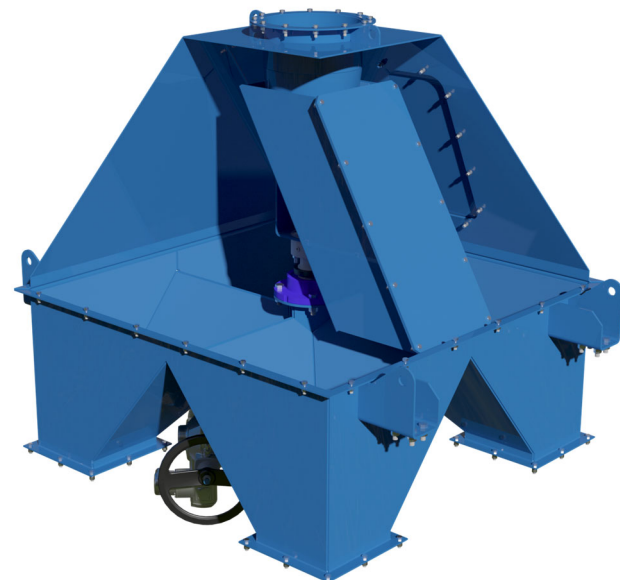



J&H Equipment, Inc.

Revolutionizing Pulverizing & Crushing Technologies

J&H MOD III HD Dual Rotor Chain Mill

FEATURES:

- Full-width, center hung side access doors that can be handled by one person
- Full-width impact pads covering the entire area for easy replacement and durability
- Chains can be inspected or replaced without disassembly of other parts of the mill
- The only rotor in the industry that requires no disassembly of shaft or bearings to remove rotor
- Solid welded construction and welded stainless steel liners in non-impact zones provide exceptional durability and life
- Live loads are almost non-existent thanks to our "floating rotor" suspension system
- Capacity in our largest 36" HD can handle up to 100 tph
- Available from 24" to 36" according to capacity requirements

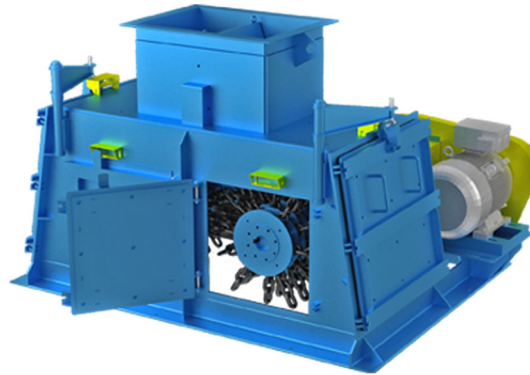

The J&H HD Chain Mill is driven by two electrical motors ranging in power from 25 to 100 hp each. Built in three different designs with widths ranging in six-inch increments from 24" to 36" according to the models, available in tonnages up to 100 tph.

The J&H HD Chain Mills are designed with a cantilever mounted "floating rotor" system which reduces vibrations to an amazingly negligible amount, which allows for its implementation directly to the concrete or steel floor without the addition of costly structural considerations or isolator pads. They feature large front and rear access doors, which combined with the unique center hung full width side access doors allow quickest access for cleaning and easiest maintenance in the industry.

All chain mill body frames are solid, welded construction. All impact zones are protected with solid rubber pads covering the entire area for easy replacement and durability. On all our mills, chains can be easily inspected and removed, if necessary, without disassembly of other parts of the mill. Zero speed switch and access door proximity switches are available as options.

Incorporating over 40 years of experience, the J&H chain mills are robust, reliable, and efficient.

- The J&H Dual Rotor Chain Mill utilizes rotors equipped with chain flails rotating in opposite directions. Material is fed into the mill where it is divided and each half is directed into optimal crushing zones of each opposing high speed chain rotor. Material is impacted by chains and then propelled into path of opposing rotor and its discharging material. These opposing velocities generate unique centergistic crushing efficiency.
- The J&H Chain Mills are designed to accept materials of various hardness's and moisture contents.

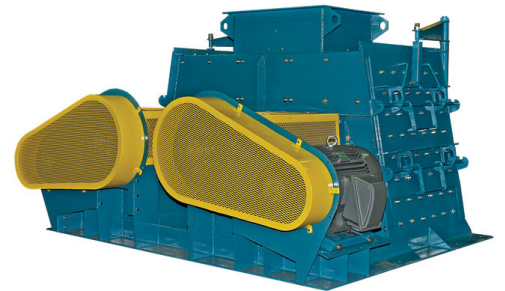



J&H Equipment, Inc.

Revolutionizing Pulverizing & Crushing Technologies

NEW AND IMPROVED DESIGN

J&H MOD III Dual Rotor Chain Mills

FEATURES:

- Vibration isolation at its best due to J&H unique floating rotor design. While operating cup of water has minimal ripple.

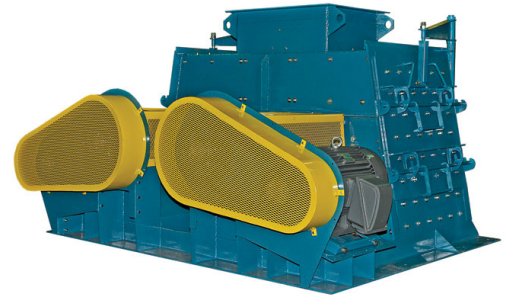
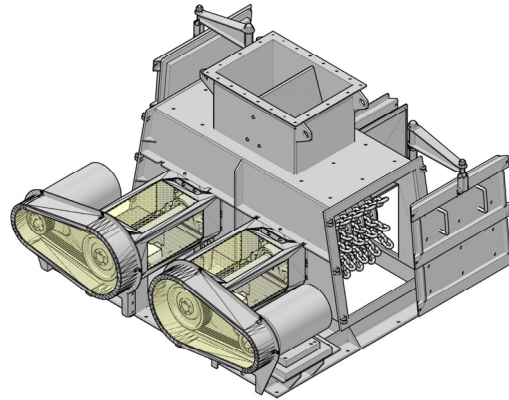
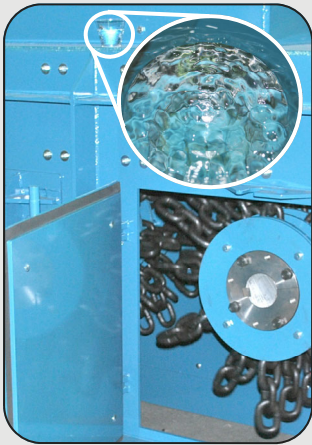

- New non-impact weld in stainless steel liners.
- New 1/2" [13mm] rubber gasket, molded as an integral part of the side access door impact pads guaranteeing no leak.
- New revolutionary solid rubber impact pads with metal backing plate and welded inserted nuts for the ease of maintenance and quick installation.

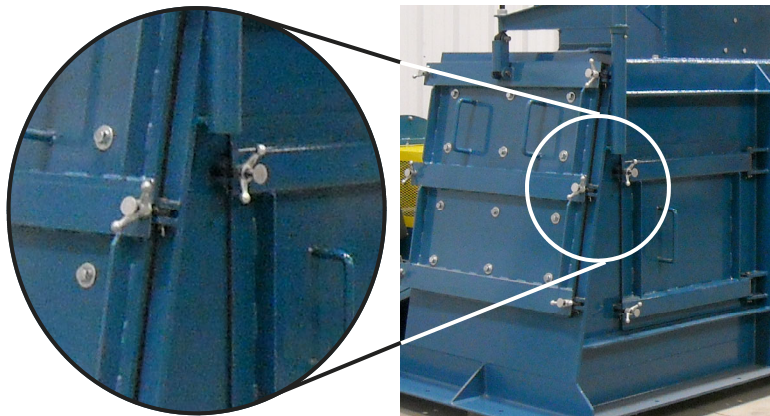

- New improved quick release locking side and front access doors with superior compression capability for no leak performance.
- Now featuring only 4 impact pads, reducing down time and maintenance cost.
- New full width center hung side doors for ease of handle and decreased access foot print..

New model impact pad consist of only 4 pads for the entire unit, minimizing hardware and decreasing installations significantly.

Previous model impact pad was 12x12 square pad with tracks for aligning spring nuts, Installation was time consuming, 30+ pads 4 bolts per pad totaling 120+ bolt assemblies.

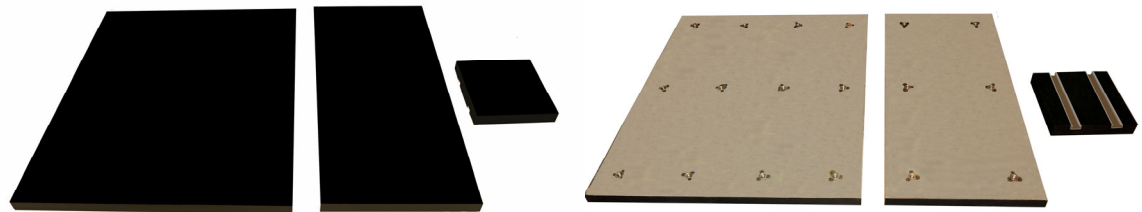

J&H Equipment Inc. • 140 Sunshine Way • Alpharetta, GA 30005 •

(770) 992-1606 • Fax (770) 992-1983

Web Site: www.jhequipment.com



J&H Equipment, Inc.

Revolutionizing Pulverizing & Crushing Technologies

FEATURES:

- Quick release, slide-out shaft
- Fixed bearings eliminate alignment problems
- Solid welded construction and welded stainless steel liners in non-impact zones provide exceptional durability and life
- Full-width specially blended rubber impact pads covering the entire impact area for easy replacement and durability
- Full-width, center hung side access doors that can be handled by one person
- Capacity in our largest 42" can handle up to 120 tph
- Available from 24" to 42" according to capacity requirements
- The number and configuration of chains are specifically determined to maintain the balance of the rotors and to increase chain life by distributing the material impact over a larger area of the chain.



J&H MOD III HDF Dual Rotor Chain Mill



- Designed for long life and ease of maintenance
- Versatile and customizable to your needs
- Manufactured utilizing state of the art robotic welders and laser cutting equipment
- The perfect solution for retro-fit applications where space is of concern

The J&H HDF Chain Mill is a dual rotor crushing machine driven by two electrical motors ranging in power from 25 to 125 hp each. Both rotors are equipped with a series of special hardened steel chain strands that are rotating in opposite directions, such opposing velocities generate a centergistic crushing zone.

HDF Chain mills are designed to reduce the size of falling material by chain and material impact. Built in four different designs with widths ranging in six-inch increments from 24" to 42" according to the models, handling capacities up to 120 tph in our largest.

Our HDF Chain Mill has a smaller footprint than our HD Chain Mill to accommodate locations where space is an issue while maintaining the same capacity and durability as the HD Chain Mill. Featuring a quick release, slide-out shaft and large access doors located on the side of the machine provide considerable access to all of the necessary points that require service. Its motors are also located on top of the mill body to maintain full accessibility to all external and internal parts of the mill.

Our HDF Chain Mill utilizes a technically proven vibration absorbing pad which is incorporated into its bottom flange. This technology combined with high-speed, balanced rotors maintains vibrations to a reduced level. Fixed bearings eliminate alignment problems.

Incorporating over 40 years of experience, the J&H chain mills are robust, reliable, and efficient.

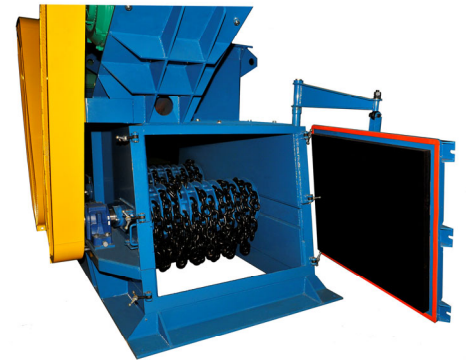



J&H Equipment, Inc.

Revolutionizing Pulverizing & Crushing Technologies

J&H Single Rotor Custom Pulverizing Mill

FEATURES:

- Small footprint , single rotor design
- Variable liner and crusher solutions depending upon your needs
- Unique “floating rotor” suspension system available in horizontal version
- Fixed bearings eliminate alignment problems
- Solid welded construction and welded stainless steel liners in non-impact zones provide exceptional durability and life
- Capacity per chain mill can be up to 12 tph
- Customizable sizes according to capacity requirements

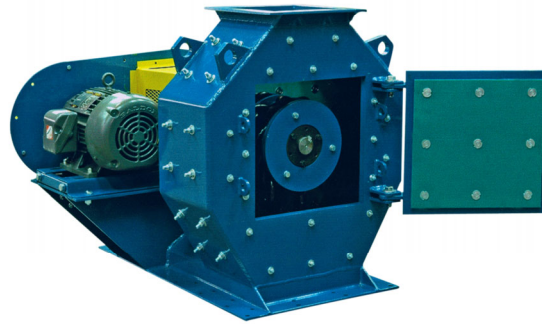

- Single rotor compact pulverizer in floating horizontal shaft and vertical suspended shaft designs
- Manufactured carbon steel and various stainless steel alloys
- Utilized in laboratory and glass recycle applications
- Numerous liner types are available dependent upon need

The J&H single rotor crushing machine is driven by one electrical motor ranging in power from 5 to 15 hp. There are two designs available each customizable to your specific needs.

The single rotor vertical mill is unique in that there are two inlets strategically located for optimal crushing efficiency. As material falls a vertical rotating rotor with hardened crushing bars pulverizes passing product. Vertical mills are available with 2”[50mm] specially formulated rubber liners or AR400 abrasion resistant steel liners depending upon the needs of your application.

Our single rotor horizontal mill utilizes the same floating rotor technology as our flagship crusher the MOD III HD pulverizing mill. These mills as well are available with 2”[50mm] specially formulated rubber liners or AR400 abrasion resistant steel liners depending upon the needs of your application.

Contact your J&H Representative to investigate how J&H can fulfill your crushing and pulverizing needs

Incorporating over 40 years of experience, the J&H pulverizing mills are robust, reliable, and efficient.

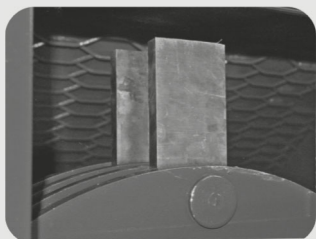
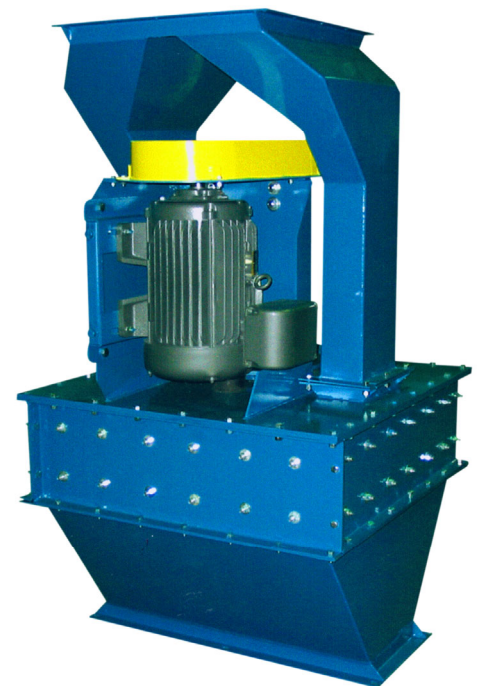



J&H Equipment, Inc.

Revolutionizing Pulverizing & Crushing Technologies

FEATURES:

- Single or double rotor
- 10-50hp motor
- Available in sizes from 18" to 60" and up
- 60 Rockwell "C" faced teeth
- AR400 replaceable comb teeth
- Split housing steel frame lined with AR400 plates
- Minimal power requirement thanks to its rotor designed to have only a few teeth engaged at the same time
- Geometry of the comb in relation to the teeth allows for finer material to pour through avoiding any bottlenecking effect
- Zero Speed Switch

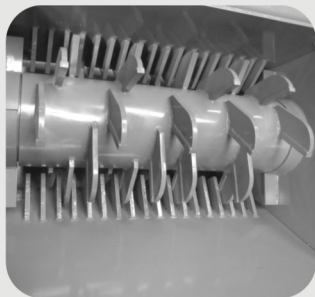
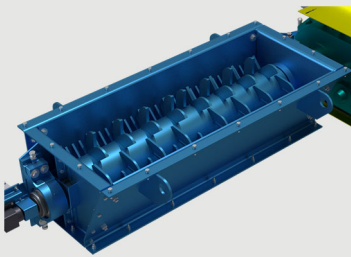

J&H Lump Breaker

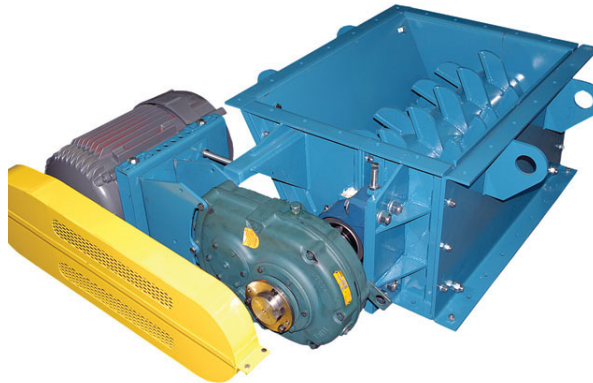

The J&H Lump Breaker is a compact machine designed with short, hardened tool steel teeth mounted on a rotating drum passing through an AR comb system. The rotor is driven by a shaft mount speed reducer in conjunction with Mill & Chem motors ranging in power from 10 to 50hp, depending on breaker capacity.

The J&H Lump Breaker's purpose is to break lumps up to 400 mm in diameter down to 25 mm or less in order to prepare material for conveying or screening while using a minimal amount of power. Its capacity can go up to 800 tph or 1500 tph for dual rotor units.

The J&H Lump Breaker is designed as an added module to the feed point of a conveyor, elevator, a dryer discharge point, or other types of mills. Built with a unique rotor design allowing only a few teeth to be engaged at the same time, this allows for minimal power requirements. Easily maintained thanks to its split design, all components are accessible without disassembly with neighboring equipment. A self-energized speed switch is coupled with the shaft to cut off the motor if the rotor is blocked or at reduced motion.

The J&H Lump Breaker is designed to yield maximum capacity with minimum power.



- Rotor equipped with hardened 60-Rockwell "C" faced teeth
- Breaker combs AR400 replaceable comb teeth



J&H Equipment, Inc.

Revolutionizing Pulverizing & Crushing Technologies

J&H HD MOD III Single Rotor Hammer Mills

FEATURES:

- Single rotor design allows for decreased footprint.
- Solid welded construction and welded stainless steel liners in non-impact zones provide exceptional durability and life.
- Full-width, side access doors that can be handled by one person.
- Full-width impact pads covering the entire area for easy replacement and durability.
- Hammers can be inspected or replaced without disassembly of other parts of the mill.
- Live loads are almost non-existent thanks to our “floating rotor” suspension system.
- Multiple sizes available according to capacity requirements.

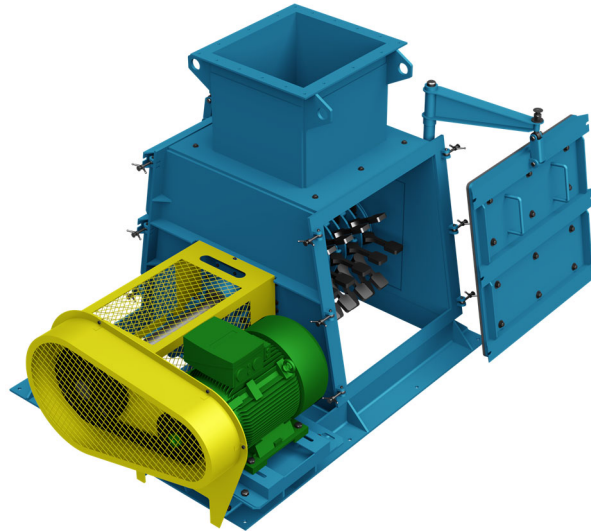

- The J&H HD Single Rotor Hammer Mill utilizes a rotor equipped with AR400 hammer flails that increase crushing surface area.
- The J&H HD Hammer Mills are designed with a cantilever mounted “floating rotor” system which reduces vibrations to a negligible amount, which allows for its implementation directly to the concrete or steel floor without the addition of costly structural considerations or vibration isolation pads.

- J&H Hammer Mills are designed to accept materials of various hardness's and moisture contents.
- The hammer mills feature a large front access door, which combined with the unique center-hung full width side access doors, allow the quickest access and cleaning and maintenance in the industry.
- All hammer mill body frames are solid, welded construction. Impact zones are protected with solid rubber pads covering the entire area for easy replacement and increased durability.
- Shaft zero speed sensors and access door proximity switches are available as options.

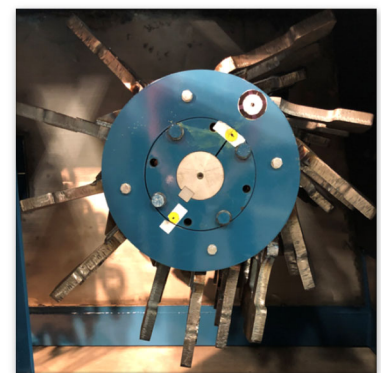
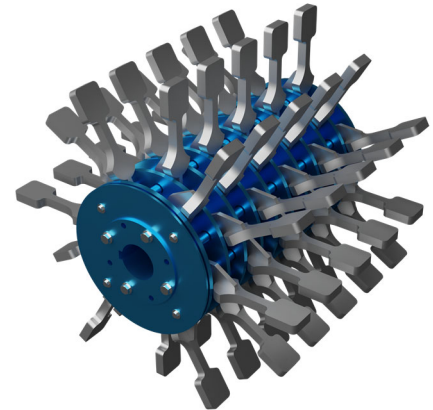

Incorporating over 40 years of experience, the J&H chain mills are robust, reliable, and efficient.





J&H Equipment, Inc.

Get The Most Out of Your Screening Machine

J&H MOD II VIBRATING SCREEN FEEDER

FEATURES:

- Feeder capacity ranges from 10 to 250 mtp/h
- Available in 48", 60", 72", and 84" widths to match any J&H screen size
- Adjustable, stainless steel, double-taper feeder pan
- Dual J&H eccentric drive motors with the J&H floating drive system
- Convenient top, rollback cover allows access to the feeder interior to view the flow of material and to perform flow adjustments
- Access doors on both sides of feeder for convenient maintenance



- Specifically designed to optimize material distribution to the J&H screening machine.
- Latest in vibration isolation technology
- Designed for long life and ease of maintenance
- Versatile and customizable to your needs
- Manufactured utilizing state of the art robotic welders and laser cutting equipment

The J&H Feeder is a totally enclosed machine with a static housing and an internal stainless vibrating pan. The machine bolts directly to any J&H screen.

It is designed to increase the efficiency of a J&H screen by distributing the flow of material over the full width of its wire cloth. The design and vibration of the pan regulate the incoming flow of material by absorbing the momentum of high velocity material or "fluidizing" slow moving material. The slope of the feeder pan is adjustable to address specific material needs and plant configuration. In addition to pan adjustment, the J&H Feeder offers adjustable deflectors to divert material flow and comes standard with access doors for ease of inspection and maintenance.

The J&H Feeder is instrumental in maximizing the wire cloth life expectancy by effectively distributing material across the full width of the screen inlet, avoiding any one direct stream of material on only a small portion of the wire cloth.

The J&H Feeder can be your solution to increasing screen efficiency.





J&H Equipment, Inc. Get The Most Out of Your Screening Machine

NEW AND IMPROVED DESIGN

J&H MOD II VIBRATING SCREEN FEEDER

The industry leader for uniform full width feeding of your J&H Screening Machine.

IMPROVED FEATURES:

- New redesigned pan take up with vibration isolation support. Eliminates suspension cable wear and fatigue, improves pan amplitude/vibration.

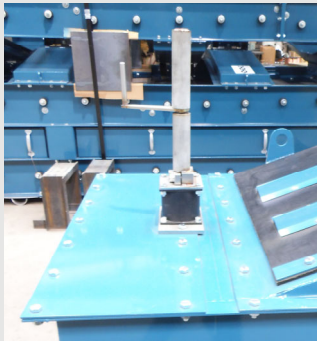
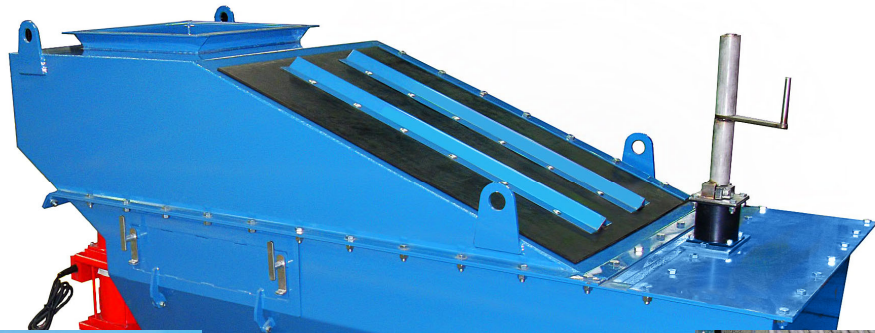

- New side entry door for ease of maintenance and improved access.
- New side access foldable rubber top covers, adjustable to either side depending upon the orientation of your feeder.
- New drive mount isolation buffers with over 400% increase in rubber cross section offer an internal hollow core for heat dissipation, increased shear action and extended life.
- Now standard with JHV 1800 vibrators generating 4 times greater amplitude at same energy consumption.

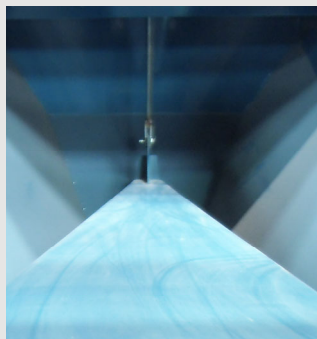
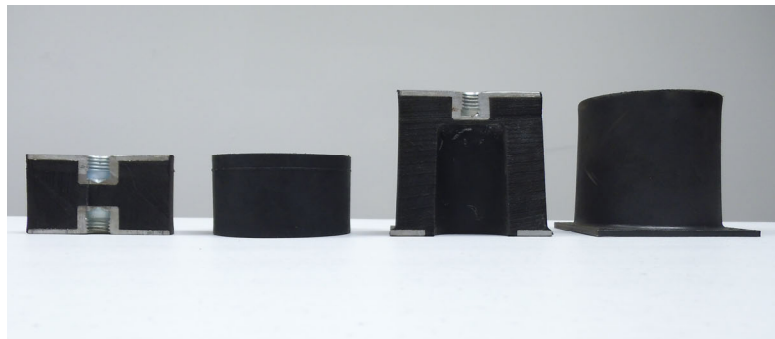
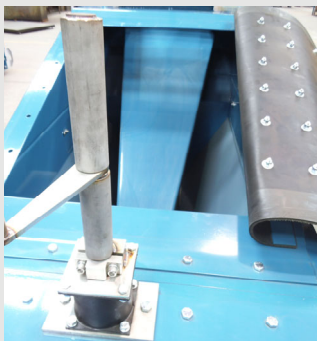

J&H Equipment Inc. • 140 Sunshine Way • Alpharetta, GA 30005 •
(770) 992-1606 • Fax (770) 992-1983
Web Site: www.jhequipment.com



J&H Equipment, Inc.

Get The Most Out of Your Screening Machine

FEATURES:

- Feeder mounts directly onto the feed inlet of any J&H screen
- Equipped with an AR360 carbon steel double taper feeder pan
- Moderate the speed of product flow entering the screen
- Adjustable flow paddles to change the flow of material across the pan
- Adjustable feed baffle to help correct large imbalances
- Pre-assembled and powder coat painted to provide maximum protection
- Equipped with fast opening latches access doors that open side-ways allowing easy observation of the flow of material
- Arrives fully assembled and ready to install

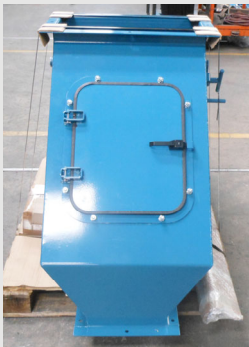

J&H CD STATIC SCREEN FEEDER

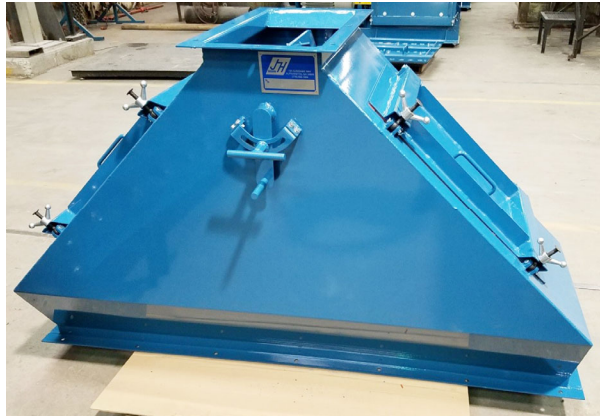

- Specifically designed to increase the efficiency of a screening machine by evenly distributing the flow of material over the full width of the screen.
- Available in 48", 60", 72", and 84" widths to match any J&H screen size
- Designed for long life and ease of maintenance.
- Access door on both sides of feeder convenient maintenance and observation of material flow.

The J&H CD Static Feeder is a machine designed to increase the efficiency of a screening machine by evenly distributing the flow of loose, dry product material over the full width of the screen's wire cloth.

The design of the pan and the interior side walls regulate the incoming flow of material by absorbing the momentum of high velocity material or "fluidizing" slow moving material. The J&H Feeder offers adjustable deflectors to divert material flow and comes standard with two access doors for ease of inspection and maintenance.

The J&H CD Static Feeder is instrumental in maximizing the wire cloth life expectancy by effectively distributing material across the full width of the screen inlet, avoiding any one direct stream of material on only a small portion of the wire cloth.

The J&H Feeder can be your solution to increasing screen efficiency.

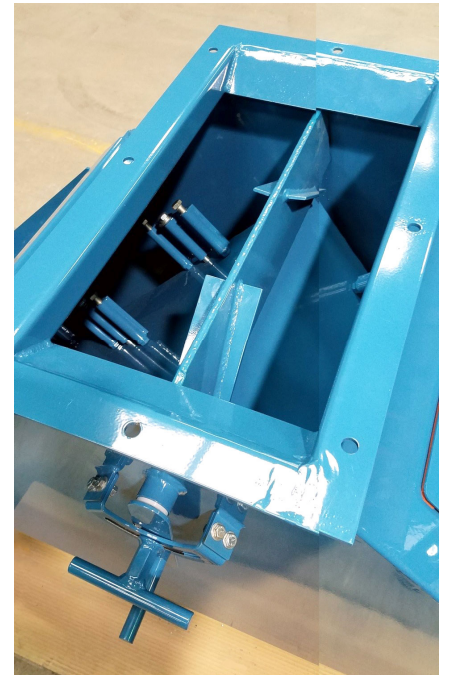

J&H Equipment Inc. • 140 Sunshine Way • Alpharetta, GA 30005 •

(770) 992-1606 • Fax (770) 992-1983

Web Site: www.jhequipment.com



J&H Equipment, Inc. Get The Most Out of Your Screening Machine

J&H CDF STATIC BODY CENTER FEEDER

FEATURES:

- The double taper feed pan allows material to flow down and spread out.
- Available in 48", 60", 72", and 84" widths to match any J&H screen size.
- All impact surfaces are lined with AR400 plates to resist wear.
- Compact and efficiently uses space to reduce the minimum the height requirements.
- Moderates the speed of the product entering by absorbing a portion of the momentum.
- Equipped with fast opening latches access doors that open side-ways allowing easy observation of the flow of material.
- Arrives fully assembled and ready to install.

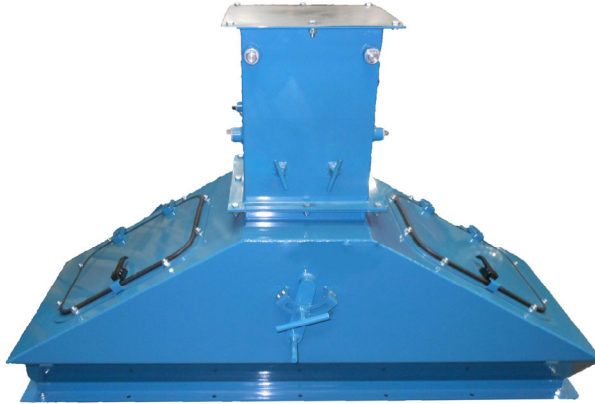

- Specifically designed to optimize material distribution to the J&H screening machine
- To help center the flow of product, the Feeder comes equipped with a deflector box which includes 4 adjustable deflectors
- Designed for long life and ease of maintenance
- Robust construction, simple but proven design
- Manufactured utilizing state of the art robotic welders and laser cutting equipment

The J&H CDF Static Screen Feeder is a machine designed to increase the efficiency of a screening machine by evenly distributing the flow of loose, dry product material across the width of the screen's wire cloth. The principle component of the J&H CDF Static Screen Feeder/Distributor is the double taper feeder pan. Product material enters the feeder at the top, and then gravity causes the material to flow down and spread out across the distributor pan allowing for an even distribution of material to the screening machine below.

The key difference between the CDF version and the CD Feeder is the lower angle of the distributor pan. The CDF's shallower pan angle was designed for materials with lower angles of repose. This design also reduces the overall height of the feeder. The J&H family of feeders are a proven solution for increasing the efficiency of your screening machine, so call today to consult with a J&H representative to identify which feeder would best fit your distributing needs.



J&H Equipment Inc. • 140 Sunshine Way • Alpharetta, GA 30005 •
(770) 992-1606 • Fax (770) 992-1983
Web Site: www.jhequipment.com



J&H Equipment, Inc. Get The Most Out of Your Screening Machine

J&H STATIC BODY CENTER FEEDER

FEATURES:

- Feeder capacity ranges from 10 to 250 mtpd
- Available in 48", 60", 72", and 84" widths to match any J&H screen size
- Dual J&H eccentric drive motors with adjustable vibratory weight settings
- Convenient all steel quick release doors allows access to the feeder interior to view the flow of material and to perform maintenance

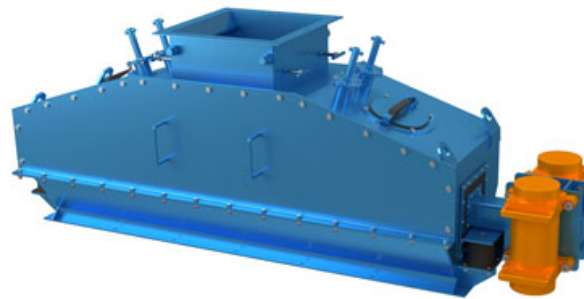

- Specifically designed to optimize material distribution to the J&H screening machine
- Latest in vibration isolation technology
- Designed for long life and ease of maintenance
- Robust construction, simple but proven design
- Manufactured utilizing state of the art robotic welders and laser cutting equipment

The J&H Static Body Center Feeder is a totally enclosed machine in which only the internal distributor pan is being vibrated. J&H proprietary isolation buffers allow maximum diverter pan vibration amplitude with negligible transmission to the feeder body. The machine bolts directly to and is supported by any J&H screen.

J&H Feeders are designed to increase the efficiency of a J&H screen by distributing the flow of material over the full width of its wire cloth. The amplitude of the distributor pan is optimized via adjustable eccentric vibratory weights. In addition to vibration adjustment, the J&H SBC Feeder offers adjustable flow deflectors to address specific material flow needs. All come standard with quick release access doors for ease of inspection and maintenance.

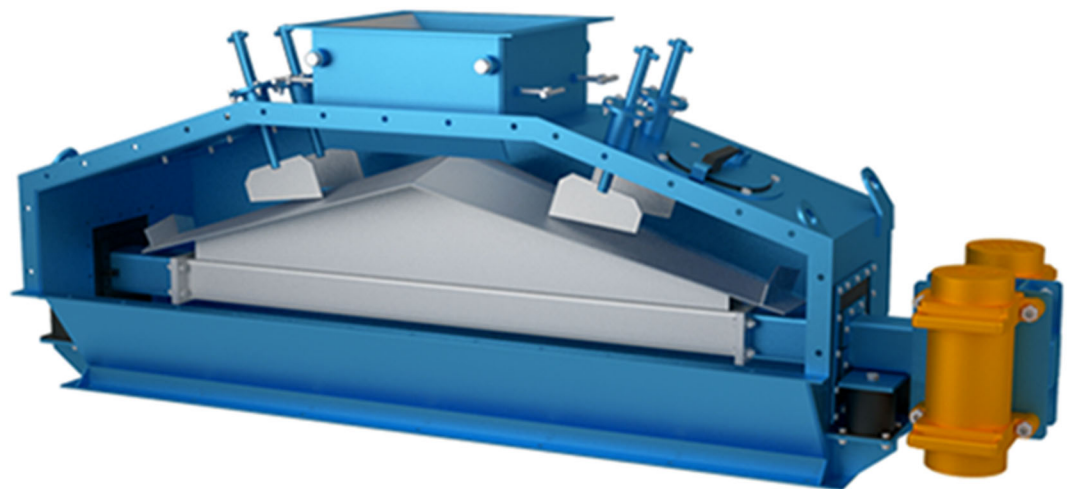
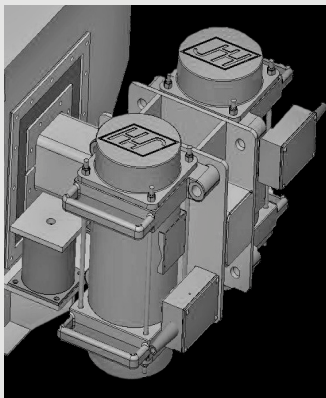

J&H Equipment Inc. • 140 Sunshine Way • Alpharetta, GA 30005 •
(770) 992-1606 • Fax (770) 992-1983
Web Site: www.jhequipment.com



J&H Equipment, Inc.

Get The Most Out of Your Screening Machine

J&H VIBRATING BODY CENTER FEEDER

FEATURES:

- Feeder capacity ranges from 10 to 250 mtpH
- Available in 48", 60", 72", and 84" widths to match any J&H screen size
- Dual J&H eccentric drive motors with adjustable vibratory weight settings
- Convenient all steel quick release doors allows access to the feeder interior to view the flow of material and to perform maintenance
- Feed and Discharge bellow packages along with mate flanges come standard with all feeders.

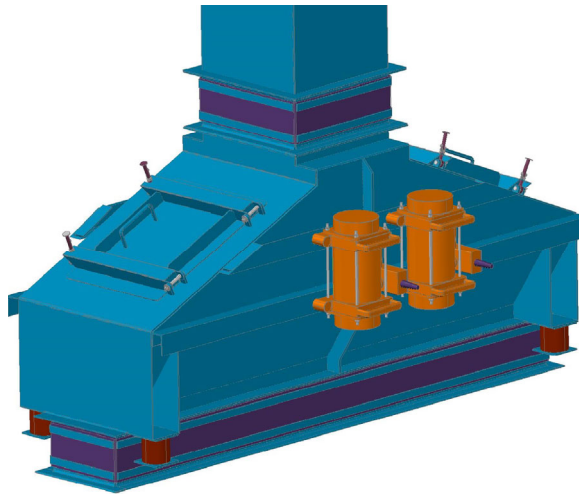
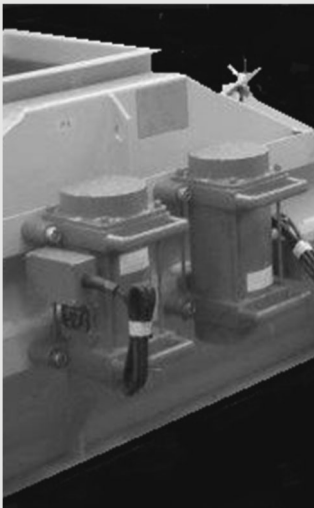

- Specifically designed to optimize material distribution to the J&H screening machine
- Latest in vibration isolation technology
- Designed for long life and ease of maintenance
- Robust construction, simple but proven design
- Manufactured utilizing state of the art robotic welders and laser cutting equipment

The J&H Vibrating Body Center Feeder is a totally enclosed machine in which the entire body and internal spreader pan vibrate as a unit. The machine bolts directly to and is supported by any J&H screen. It is mounted on four proprietary J&H vibration isolation buffers.

It is designed to increase the efficiency of a J&H screen by distributing the flow of material over the full width of its wire cloth. The vibration of the feeder is adjustable via adjustable eccentric vibratory weights which can address specific material flow needs. In addition to vibration adjustment, the J&H VBC Feeder offers adjustable feed deflectors to divert and center material flow. All come standard with access doors for ease of inspection and maintenance.

The J&H VBC Feeder is instrumental in maximizing the wire cloth life expectancy and screening efficiency.

The J&H VBC Feeder is a proven solution for Vibrating Body Feeders, call today.





J&H Equipment, Inc.

Your Solution for Conveying Material Feeders

J&H CONVEYING MATERIAL FEEDER

FEATURES:

- Feeder capacity ranges from 10 to 250 mtph
- Available in multiple sizes to meet your needs
- Adjustable, stainless steel material deflectors are available for flow adjustments
- Dual J&H eccentric drive motors
- Access doors throughout feeder for convenient maintenance



- Designed to convey material while minimizing vibration transmission, static body, vibrating/conveying pan
- Also available in vibrating body design, vibration is isolated via springs or buffers
- Designed for long life and ease of maintenance
- Versatile and customizable to your needs
- Manufactured utilizing state of the art robotic welders and laser cutting equipment

The J&H Conveying Feeder is designed in one of two ways. As a totally enclosed machine with a static housing and an internal stainless vibrating pan or as a vibrating body with vibration isolation spring buffers.



It is designed to convey material with minimal energy requirements. The design and vibration isolation technology used guarantee negligible load stresses at high amplitude conveying rates. The J&H Feeder offers adjustable deflectors to divert material flow and comes standard with access doors for ease of inspection and maintenance.

The J&H Feeder is instrumental in maximizing distribution of material.

The J&H Conveying Feeder is a proven solution to your material distribution needs.

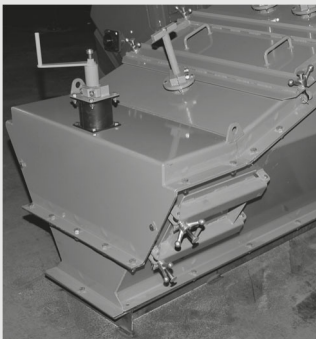
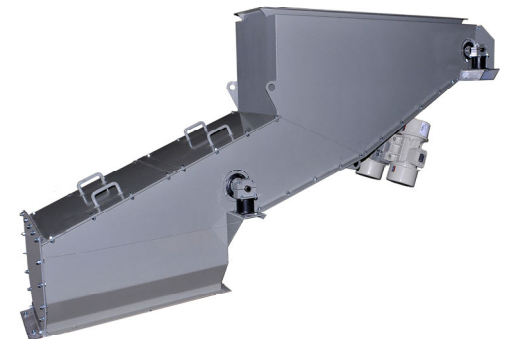



J&H Equipment, Inc.

Improve and Enhance Operation Efficiency

J&H Velocity Breaker

FEATURES:

- Shipped completely assembled
- Can be installed anywhere that material velocity is a problem
- Welded, stainless steel or hardened steel plates on all impact zones
- Powder coated finish for superior protection
- Designed as an added module to any J&H Feeder
- Large access door for easy inspection.



- Module can be mounted directly onto feed inlet.
- Reduces the speed of material in plants configuration where material is allowed to generate excessive velocity.
- Reducing the speed of the material improves the optimal velocity for screening efficiency.
- Ability to adjust orientation at assembly for maximum efficiency.
- The housing of is made of welded, carbon steel plates and is powder coated for superior protection against wear and corrosion.

The J&H Velocity Breaker is designed to improve the operation of and extend the life of a J&H feeder/distributor by reducing the impact and speed of loose, dry product material into the inlet of the feeder.

The J&H Velocity Breaker is intended to be used any time that the product material entering into the J&H feeder has excessive velocity due to a large height differential from the screen splitter valve to the screen feeder. The height of the J&H Velocity Breaker helps to reduce the angle of the distribution chutes. The velocity breaker is designed with a series of inclined impact plates that absorb the force of the material flow.

The inlet and discharge flange of the velocity breaker are identical to the inlet flange for the feeder. Since the flanges have a square bolt pattern, the velocity breaker can be turned to match the angle of the feed chute to get the greatest effect. The discharge of the velocity breaker mounts directly onto the feed inlet of the J&H feeder/distributor.

Incorporating over 40 years of experience, the J&H Velocity Breaker is a proven solution to reducing the impact and speed of loose, dry material.

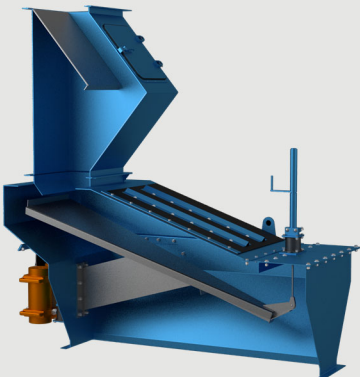
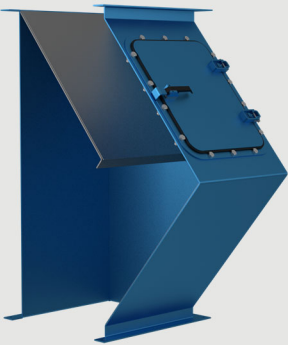
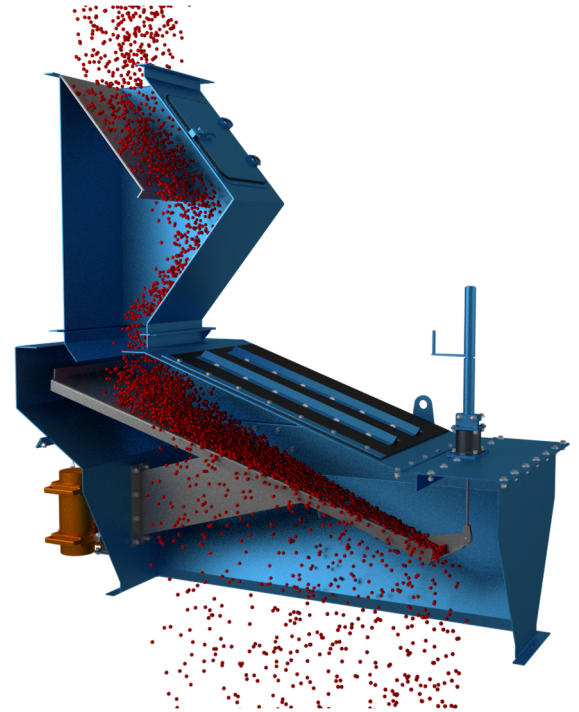

J&H Equipment Inc. • 140 Sunshine Way • Alpharetta, GA 30005 •

(770) 992-1606 • Fax (770) 992-1983

Web Site: www.jhequipment.com



J&H Equipment, Inc.

Get The Most Out of Your Screening Machine

J&H STATIC BODY SIDE-FED (SBS) FEEDER

FEATURES:

- New and improved drive assembly
- Removable side access doors for ease of maintenance
- Improved drive seals
- Directly affixes to any J&H screening machine
- Lateral or center feeder options available

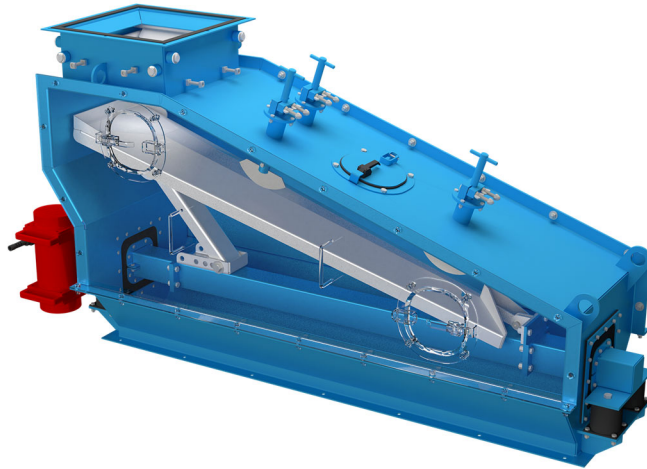

- The SBS Feeder has a direct drive linear vibrating pan incased in a static body, which allows equal and uniform distribution to the whole width of the screening machine.
- The vibrating pan and plunging deflectors are adjustable to meet the needs of the flow of material.
- The feeder is equipped with both side and top doors for quick access and simple inspections.
- Can be retrofitted to replace any previous J&H feeder model with no chute or mount modifications required.
- The SBS Feeder is installed with JHV 1800 vibrators which generate higher amplitude at a low energy consumption.
- A improved buffer design featuring a hollow core gives this feeder a longer life and more action.
- Available in J&H standard corrosion resistant industrial powder coat and our newest severe duty powder coat for toughest applications.

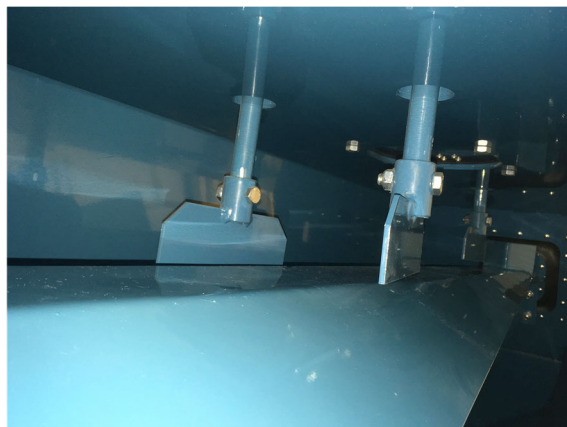

(Interior adjustable vibrating distribution)



The J&H Feeder can be your solution to increasing screen efficiency.

J&H Equipment Inc. • 140 Sunshine Way • Alpharetta, GA 30005 •

(770) 992-1606 • Fax (770) 992-1983

Web Site: www.jhequipment.com



J&H Equipment, Inc.

The "Spinden" Mixing Technology Refined

FEATURES:

- Flexible chemical resistant self cleaning trough
- Chemical resistant coated shaft and cover assembly
- Stainless alloy internal metal components for long service life
- Class II direct coupled gearing
- Rigid structural steel support frame assembly to insure proper alignment and support of trough and drive system
- SKF heavy duty roller bearing adaptor mount pillow block bearings for 40,000+ hours service life



J&H Spinden *(Under License from JSA)*

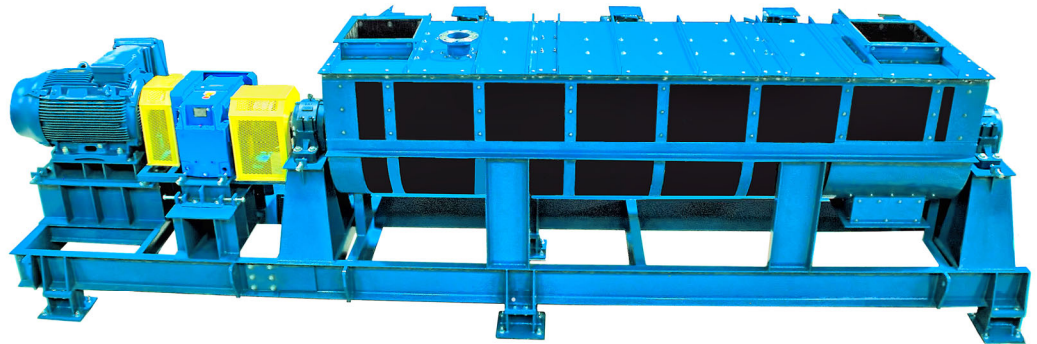

The Spinden Reactor is a paddle/pin mixer designed for continuous granulation of raw materials and recycle slurry to generate DCP and MCP as desired.

The reactor shaft and paddles are direct driven through a direct coupled Class II reduction gear and a severe duty 1.15 service factor motor. RPM is controlled by a customer provided variable speed drive which provides soft start and an operating range of 70-300RPM for standard units.

The material being mixed in the reactor has thixotropic properties - behaving as a solid or a liquid depending on the pressure applied to it. For this reason, rigid casings can cause the material to quickly build up and jam the rotor. This problem is avoided by constructing the reaction chamber from a flexible chemical resistant rubber. The rubber is resistant to acids, is basically self-cleaning, and does not sacrifice process efficiency.

The top cover plates, end plates, and shaft are lined with the same or like chemical resistant rubber that seals the reaction chamber and protects the metal structure of the reactor.





J&H Equipment, Inc. Product Sampling Simplified

J&H Automatic Product Sampler

FEATURES:

- Includes a washdown ready control box mounted directly on the drive
- Robust, reliable, and easy to install, maintenance, and operate
- Includes a remote or control room mounted timer control box
- Allows adjustments of sample quantity and frequency, depending on requirements for your application
- Available in multiple size to fit your plants needs

APPLICATIONS:

- Any industry where product speciation is a priority
- Ideal for bagging applications, load out, or product storage

The J&H Automatic Sampler enables users to test the quality of dry bulk product by taking a sample from a falling stream of material. This unit is compact, efficient and dependable incorporating a proven drive system with no critical exposed shafts or glide rails. The samplers are easy to install, made from durable carbon steel, and are made to order to fit the requirements of any plant layout, chute size and orientation, and type of product material. The compact design incorporates a low-maintenance drive system that is fully enclosed and features a heavy-duty, double flange gear box coupled with a mill and chemical "C" face motor.

Sample frequency and quantity are adjustable to fit specific sampling needs. Sample intervals can be set to any point between 2 and 30 minutes.

The Sampler is versatile in that can be operated locally or via DCS. Unit allows adjustments of sample quantity and frequency depending upon location and application.

The Sampler is ideal for bagging application or product storage applications.

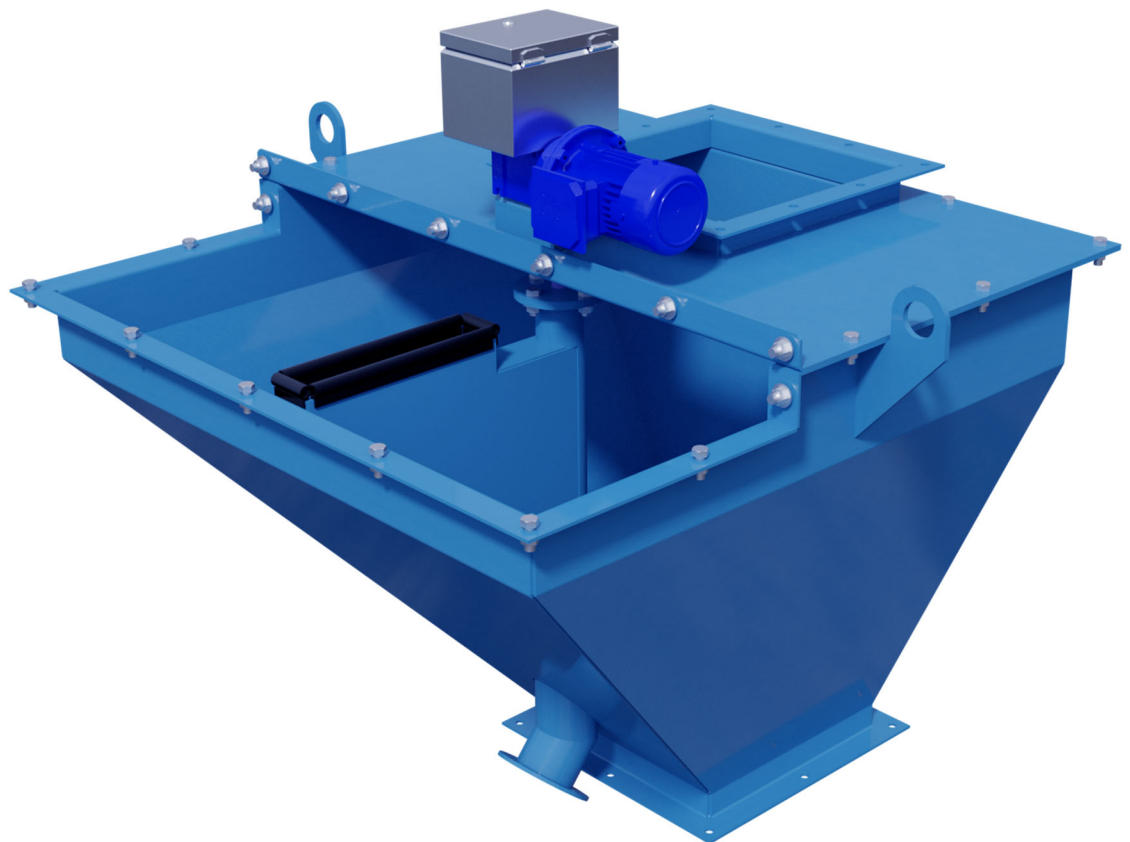

J&H Equipment Inc. • 140 Sunshine Way • Alpharetta, GA 30005 •

(770) 992-1606 • Fax (770) 992-1983

Web Site: www.jhequipment.com



J&H Equipment, Inc.

The World Leader in Vibrating Wire Screens

Product Research and Testing Lab

FEATURES:

- Batch loaders for easy analysis of material samples
- Continuous loop process screen for evaluating the performance and efficiency of any customer product
- Latest in technology for particle size analysis
- Full inventory of wire mesh to meet your testing needs
- On site research and development available for your specific needs
- Industry leading design experts available to advise your process needs



J&H will do the task of determining which wire cloth mesh for J&H Screen machines is most appropriate for your application. We have set up a research and test lab with two batch loaders and one continuous loop process screen for evaluating the performance and efficiency of any customer product.

Our lab is equipped with mesh sifters and other equipment to technically evaluate your product to determine initial particle size percentages and particle size distribution after screening. This way, we can verify that the mesh that we recommend will work as expected for your product and provide the highest processing efficiency.

Contact J&H for instructions on providing the material to us, or make an appointment to visit the climate controlled lab yourself to see a demonstration. The facility is located adjacent to our company headquarters and manufacturing shop in Alpharetta, Georgia.

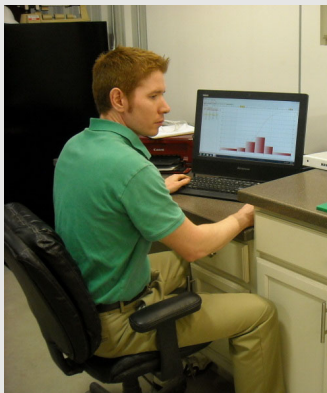

J&H Equipment Inc. • 140 Sunshine Way • Alpharetta, GA 30005 •
(770) 992-1606 • Fax (770) 992-1983
Web Site: www.jhequipment.com



J&H Equipment, Inc.

The World Leader in Vibrating Wire Screens

Capabilities and Facilities

Equipment List:

- 6 Laser Cutting Stations
- 6 Tube Fabrication Stations (Bending/Rolling)
- 4 Punching Stations
- 5 Saw Cutting Stations
- 10 Brake/Forming Stations
- 15 Milling/Machining Stations
- 2 Robotic Weld Stations
- Multiple Tig and Mig Welding Stations
- Multiple Overhead Cranes
- Assembly Facility
- Quality Control Facility
- Power Coating Facility



J&H Equipment uses some of the most advanced technologies for fabrication of our machines and parts. Items are cut using any one of five computer controlled laser cutters and automated loader which, as shown above, allows lasers to work through the night when scheduling demands it. Plate thickness from gauge to 1" can be cut into any shape required.

In addition to laser cutters, other support equipment includes CNC: shears, band saws, punches, milling machines, and four computer controlled press breaks.

Also in use are two state of the art robotic fusion welders for high quality repetitive precision welds. These are particularly good for fabricating large quantities of identical components, such as the steel buckets for our bucket elevators.

The high quality of our fabrication directly translates into the exceptional quality of every J&H Product.





J&H Equipment, Inc. Worldwide Users List



J&H Around the World
Product Users List

N. America (US, Canada, Mexico)

Phosphate, Fertilizers
Glass / Waste Recycle
Roofing / Frac Sand
Minerals

S. America (Brazil, Argentina, Columbia, Venezuela)

Phosphate, Fertilizers
Minerals

Europe (UK, Turkey)

Phosphate, Fertilizers
Minerals

N. Africa (Morocco, Egypt)

Phosphate, Fertilizers

S. Africa

Phosphate, Fertilizers

Middle East (Saudi Arabia, Pakistan)

Phosphate, Fertilizers
Minerals

India

Phosphate, Fertilizers
Minerals

China

Phosphate, Fertilizers
Minerals

South East Asia (Vietnam, Indonesia, Malaysia, Thailand)

Phosphate, Fertilizers
Minerals

Australia

Phosphate, Fertilizers
Minerals

	ELEVATORS	SCREENS	FEEDERS	DIVERTERS / SPLITTERS	CRUSHING MILLS	MIXER / GRANULATORS
Phosphate, Fertilizers	█	█	█	█	█	█
Glass / Waste Recycle	█	█	█	█	█	█
Roofing / Frac Sand	█	█	█	█	█	█
Minerals	█	█	█	█	█	█
Phosphate, Fertilizers	█	█	█	█	█	█
Minerals	█	█	█	█	█	█
Phosphate, Fertilizers	█	█	█	█	█	█
Minerals	█	█	█	█	█	█
Phosphate, Fertilizers	█	█	█	█	█	█
Phosphate, Fertilizers	█	█	█	█	█	█
Minerals	█	█	█	█	█	█
Phosphate, Fertilizers	█	█	█	█	█	█
Minerals	█	█	█	█	█	█
Phosphate, Fertilizers	█	█	█	█	█	█
Minerals	█	█	█	█	█	█
Phosphate, Fertilizers	█	█	█	█	█	█
Minerals	█	█	█	█	█	█